

SUCCESSION[®] featuring StageLock[®] Technology

TTC NAIL SYSTEM

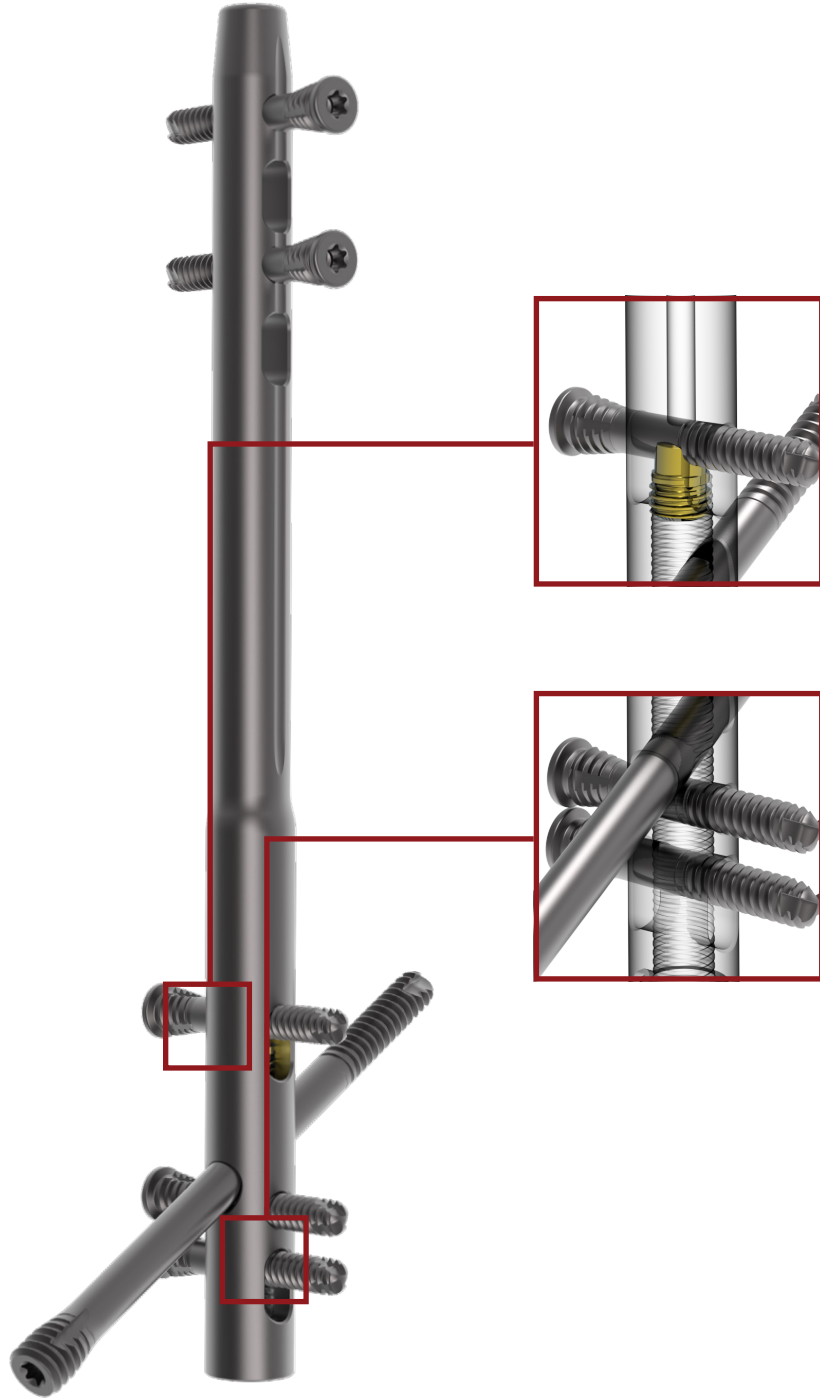

OrthoSolutions [®]
Group

Advancing Foot & Ankle Care

TABLE OF CONTENTS

Introduction

Design Goal	2
-------------------	---

TTC Arthrodesis Using the SUCCESSION[®] TTC Nail

Preoperative Planning	3
Patient Positioning	3
Surgical Exposure	4
Fusion Site Preparation	4

SUCCESSION[®] TTC Nail System

SUCCESSION [®] TTC Nail System Advantages	5
SUCCESSION [®] TTC Nail Features	6
Primary Jig Overview	7
End Cap Overview	8
Use of Primary Jig for Starter Wire Placement	9
Freehand Starter Wire Placement	10
Entry Reaming	11
Flexible Reaming	12
Nail Selection	13
Outrigger Assembly	14 - 15
Outrigger Labelling	16
Outrigger Rotation	17
Outrigger Alignment Check.....	18 - 19
Gold Clip Removal	20
Nail Insertion	21
Nail Rotation	22
General Instrumentation Guidance	23
Proximal Tibial Screw Insertion	24
StageLock [®] Compression Options	25
Full Internal Compression	26 - 30
Hybrid Internal Compression	31 - 33
Full External or No Compression	34 - 35
PA Screw Insertion	36
Outrigger Removal	37
End Cap Insertion	37
Implant Removal	37
Talar Screw First / Anterior Approach	38 - 46

Tray Layout

Top Level	47
Bottom Level	48

The medical professional is responsible for following proper surgical procedures and techniques. The guidelines provided below are intended solely for informational purposes. Each surgeon should assess the suitability of these procedures based on their own medical training and experience. Before using the system, it is recommended that the surgeon review the Electronic Instructions for Use (eIFU) available at orthosol.com/eIFU. If a hard copy IFU is required or for details on product availability in your region, please reach out to us.sales@orthosol.com.

INTRODUCTION

OrthoSolutions[®] is a specialist orthopedic foot and ankle company that works in partnership with surgeons to design and develop implants and instrumentation for patients worldwide.

As one of the longest established foot and ankle companies globally, OrthoSolutions[®] brings 20+ years of experience of working with leading surgeons to deliver evidence-based advances that enable consistent patient outcomes.

DESIGN GOAL

Tibiototalcalcaneal (TTC) arthrodesis has been shown to be a successful treatment for patients with severe pain and/or functional disability. Combined fusion of the ankle and subtalar joints is often used in these complex cases, with significant bone loss and/or deformity.

The SUCCESSION[®] TTC Nail System was developed with the goal of providing a straightforward and versatile solution for the internal fixation of the ankle and subtalar joints - allowing for independent stabilization of each. The system was designed by highly experienced surgeons who have closely followed the evolution of hindfoot nailing and recognized the limitations of existing systems.

Based on their extensive experience, the design surgeons created the SUCCESSION[®] TTC Nail System to deliver a straightforward and consistent surgical experience - critical for patients with complex anatomy, compromised bone quality, and/or significant deformities.

PREOPERATIVE PLANNING

Preoperative planning is based on the discretion of the surgeon.

The appropriate nail size should be carefully considered during preoperative planning. Measure the intra-medullary canal on AP and lateral views of the tibia on tibia-fibula films to estimate the most suitable nail diameter. The SUCCESSION® TTC Nail System provides a range of nail lengths from 190mm to 250mm and is available in diameters of 10.0mm, 11.0mm, and 12.0mm.

PATIENT POSITIONING

Patient positioning is based on surgeon preference and may depend on the pathology and/or previous surgical approaches for a particular patient. Patient positioning options include supine with an ipsilateral bump, lateral decubitus, or prone.

A radiolucent table is recommended for this procedure. Prepare the entire foot and lower limb such that the patient is draped above the knee and visualization of the knee and lower limb is present to allow for assessment of lower limb alignment. The distal limbs should extend just over the operating room table. A large C-arm should be available for entry over the operative site from the contralateral side.

SURGICAL EXPOSURE

Tip: When selecting the optimal surgical approach, aim to use existing incisions when possible. Generally, the most effective approach is the one the surgeon is most experienced with.

LATERAL APPROACH

The upper limit of the fibular incision should be at least 2cm above the level of the tibial plafond. Continue the incision over the fibula curving anteriorly at the tip of the fibula towards the base of the 4th metatarsal.

The fibula is divided proximal to the tibial plafond. The fibula is mobilized, and the distal ligaments transected. The fibula is removed allowing access to the subtalar joint. Cancellous bone can be harvested from the resected fibula and utilized as bone graft.

A separate anteromedial approach to prepare the medial malleolus may be required.

ANTERIOR APPROACH

An anterior longitudinal incision should be made approximately 1cm lateral to the tibial crest, centered over the extensor hallucis longus (EHL) tendon. The EHL tendon is retracted laterally to allow access. Care must be taken distally to avoid injury to the superficial peroneal nerve. A capsulotomy is then performed to expose the tibiotalar joint, including both medial and lateral gutters.

For subtalar joint exposure, a separate lateral incision may be made just anterior to the peroneal tendons, beginning at the tip of the fibula and extending approximately 4-5cm.

FUSION SITE PREPARATION

An ankle arthrodesis joint preparation is performed in the standard manner, thoroughly preparing the joint surfaces using a combination of osteotomes, chisels, burrs and drill bits. Fluoroscopy guidance can be helpful. A separate anteromedial incision over the medial gutter often helps. The medial malleolus is preserved as a medial buttress.

The subtalar joint is prepared in a similar fashion, paying attention to the anterior, middle and posterior facets.

It is crucial to reduce and align the hindfoot directly beneath the tibia. The foot should be positioned so that, when the patient is standing, it rests flat on the ground across all planes. Difficulty in reducing the subtalar joint may indicate that the anterior or middle facet, or the posteromedial corner of the posterior facet, has not been adequately resected.

The foot should be positioned in neutral or slight external rotation referencing from the tibial tuberosity at the knee.

Tip: Ankle and subtalar joint preparation are crucial to successful fusion. Take care to avoid excessive bone resection which may result in limb shortening or inadequate talar fixation.

SUCCESSION[®] SYSTEM ADVANTAGES

- StageLock[®] provides controlled internal independent compression at the tibiotalar joint (Stage 1) and talocalcaneal joint (Stage 2)
- Primary Jig provides reproducible positioning of the guide wire, and, ultimately, the nail
- Carbon Fiber Outrigger Jig is radiolucent and provides quick and easy rotation of the radial arm through medial, posterior, and lateral positions
- Impactor deflects the Olive Reaming Rod during Nail insertion to allow axial force to be applied with a mallet without contacting the rod
- Each screw is designed with an optimized core diameter to deliver increased strength in critical load-bearing areas
- 6mm PA screws in the calcaneus and across the subtalar joint for rigid fixation
- PA Screw is a 30° oblique screw inserted from the calcaneus to the talus
- 5mm cortical screws in the tibia and talus for a strong construct

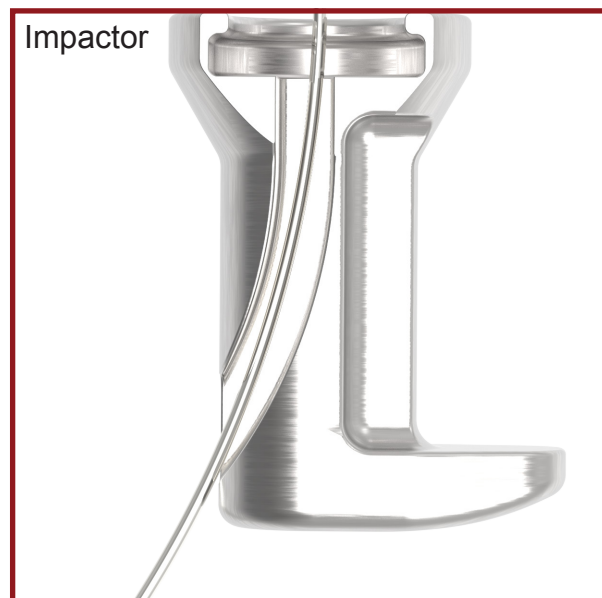
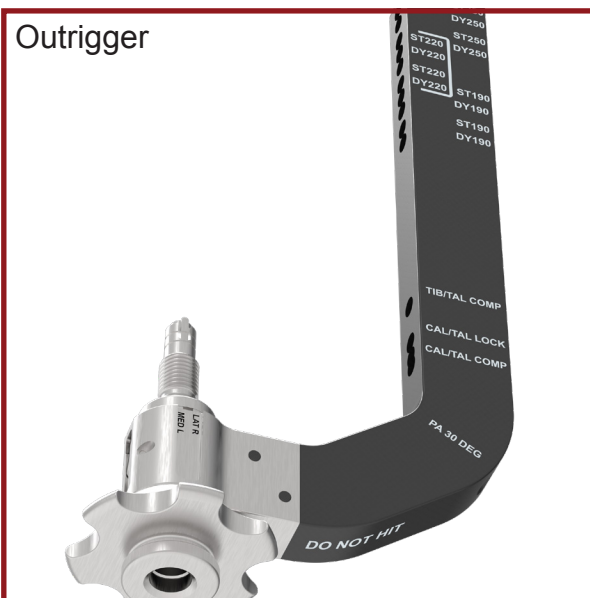
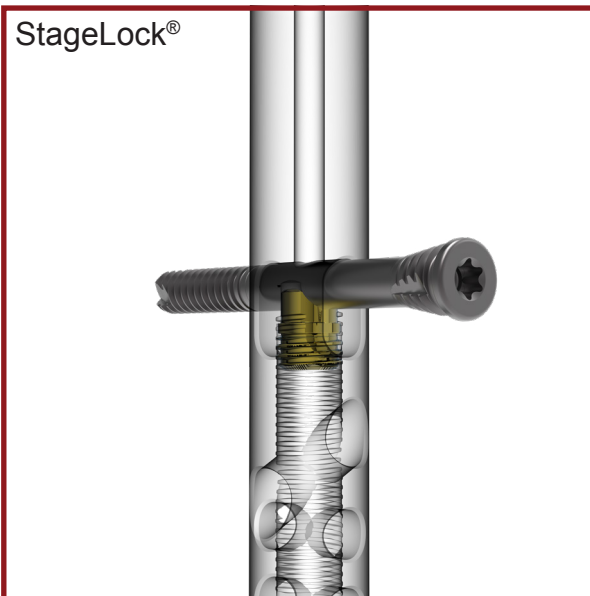

SUCCESSION[®] TTC NAIL FEATURES

- Constructed from Type II anodized titanium alloy
- StageLock[®] Compression features a cradle within the nail that allows controlled internal compression
- The distal diameter of each nail is 12.5mm to ensure strength through the ankle joint
- Diameters include: 10.0mm, 11.0mm, and 12.0mm
- Lengths include: 190mm, 220mm, and 250mm

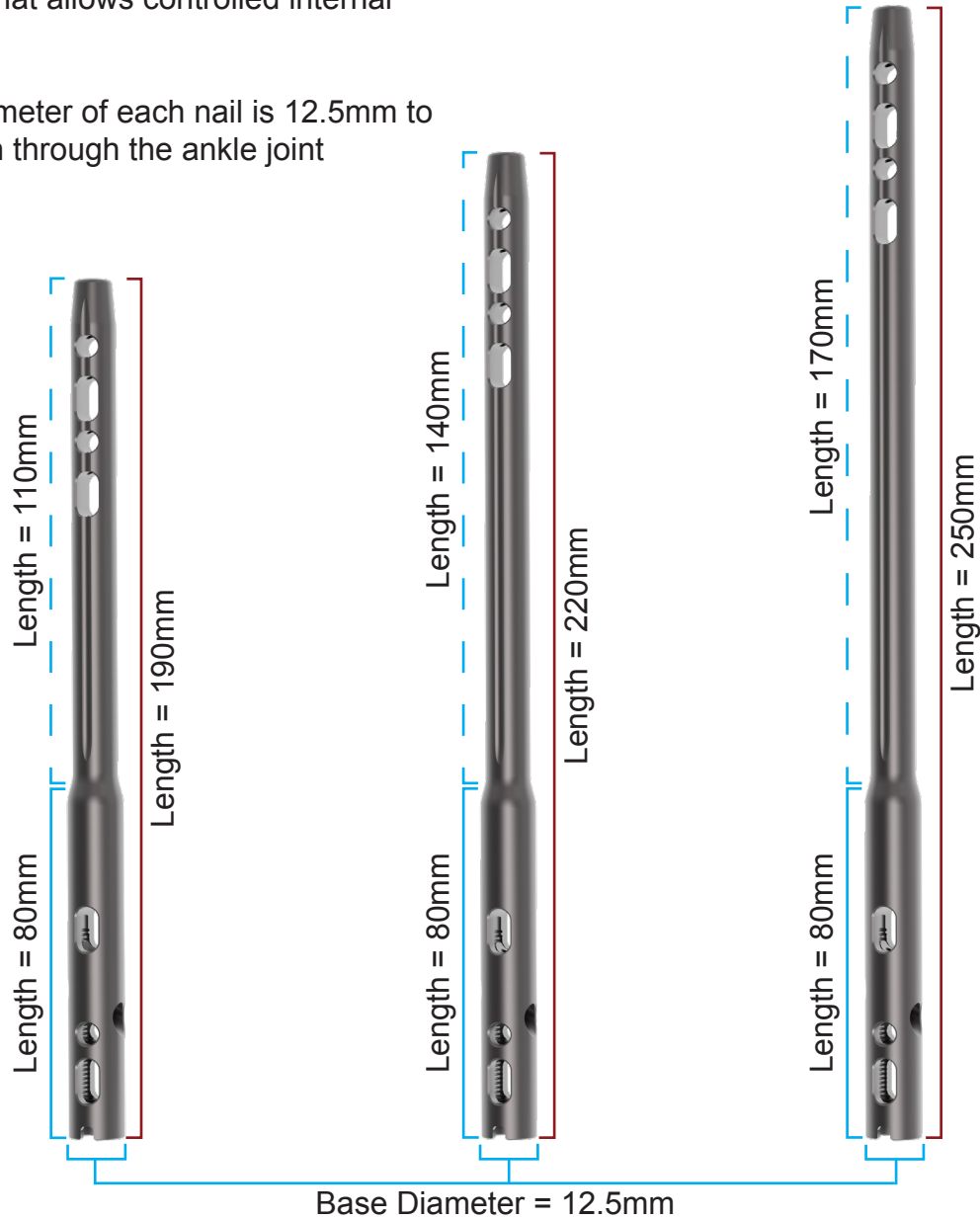

		LENGTH		
		190mm	220mm	250mm
PROXIMAL DIAMETER	10.0mm	●	●	●
	11.0mm	●	●	●
	12.0mm	●	●	●

Tip: Only the proximal diameter of the Nail is changing.

PRIMARY JIG OVERVIEW

- The Primary Jig is an optional instrument used to guide the initial placement of the 3.2mm Starter Wire in the distal to proximal direction
- Designed to reduce the number of attempts of the Starter Wire to set the trajectory of the Nail
- The “fork” at the proximal end of the jig stabilizes wire alignment, enabling precise targeting through the center of the talus and accurate tibial entry, and is easily visible under fluoroscopy

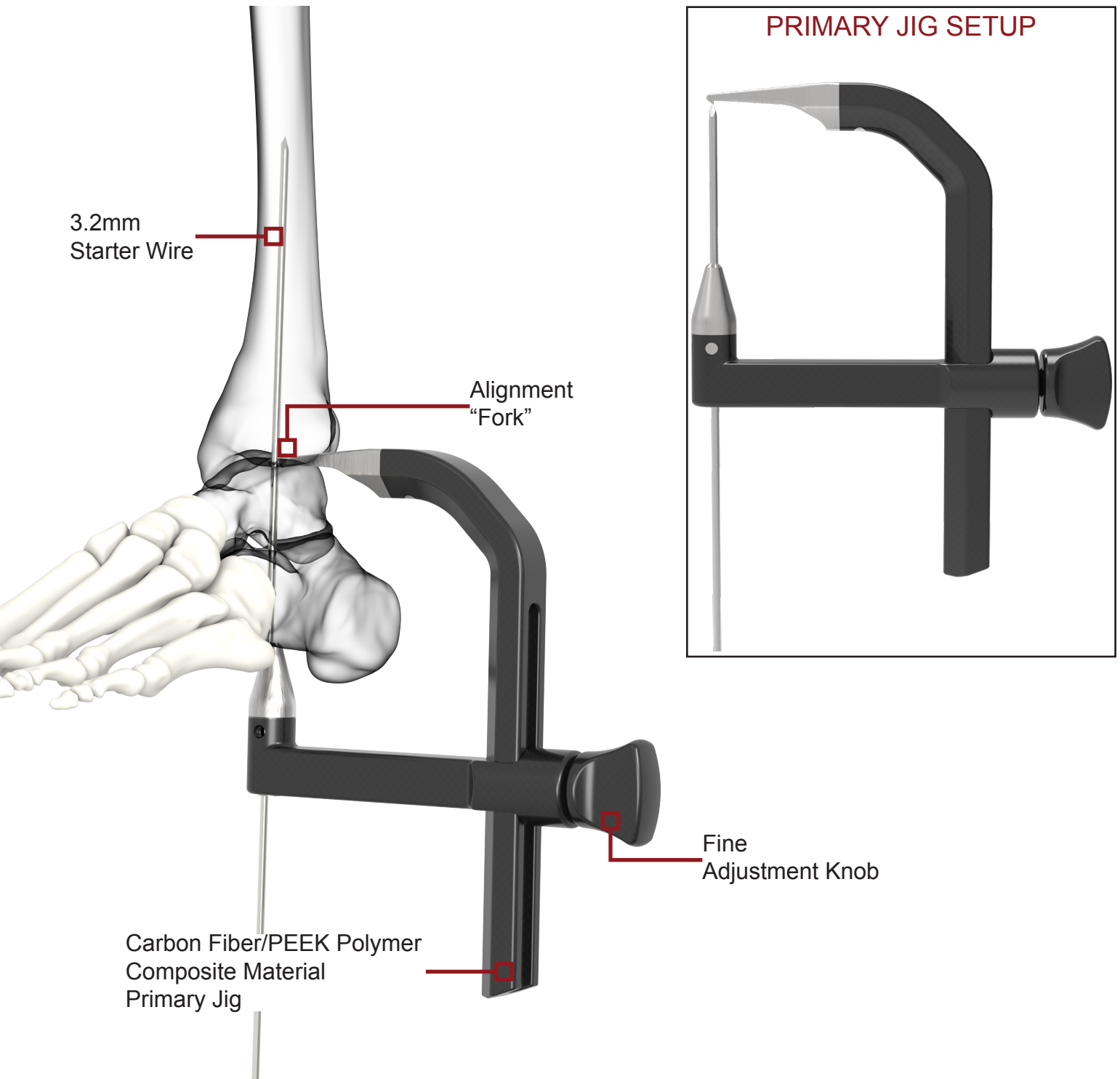

END CAP OVERVIEW

It is recommended that an End Cap is inserted into the Nail after PA Screw placement and Outrigger removal. The purpose of the End Cap is to inhibit fibrous and bony in-growth into the Nail, which makes removal (if needed) difficult.

SHOULDERED END CAP



- May be used in conjunction with the internally compressed screw (Stage 2)
- The 5mm shoulder (top image) and 10mm shoulder (bottom image) correspond to the countersunk depth of the nail

LOCKING END CAP



- End Cap applies pressure to the distal L/M Screw to enhance the stability of subtalar compression (Stage 2)



Ø12.5mm x 5mm



Ø12.5mm x 10mm



Ø12.5mm Locking

USE OF THE PRIMARY JIG FOR STARTER WIRE INSERTION

1. Position the proximal end of the Primary Jig central to the talar head. This positioning is critical to ensure accurate wire alignment through the tibial canal.

2. Once the proximal end of the Primary Jig is set, position the distal end approximately 2cm plantar to the fat pad of the heel.

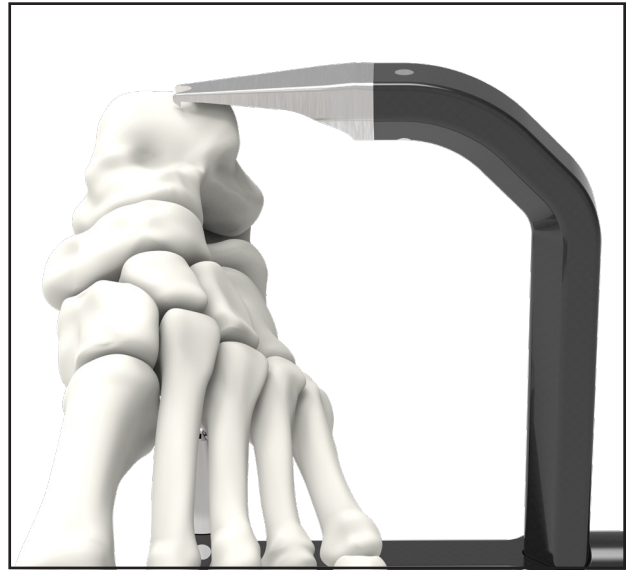

3. A plantar incision is made just distal to the plantar fat pad, slightly lateral to midline. Blunt dissection is carried down to the plantar calcaneus to avoid disruption of nearby neurovascular bundles. The tip of the 3.2mm Starter Wire is placed against the plantar aspect of the calcaneus.

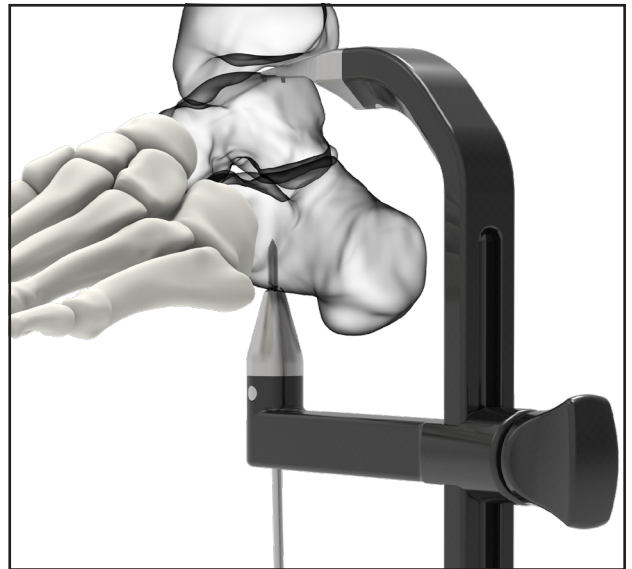

Tip: A lateral fluoroscopic image may be utilized to confirm correct distal to proximal trajectory of the Starter Wire.

Note: When utilizing the anterior approach, position the Primary Jig medial to the first metatarsal to minimize displacement caused by soft tissue interference. (Page 40)

4. Once the correct starting point is confirmed on lateral fluoroscopy, advance the 3.2mm Starter Wire through the calcaneus, talus, and into the tibia, using AP, lateral, and calcaneal axial fluoroscopic views throughout the process. Ensure that the Starter Wire remains centered within the calcaneus, talus, and tibia, terminating in the tibial medullary canal.

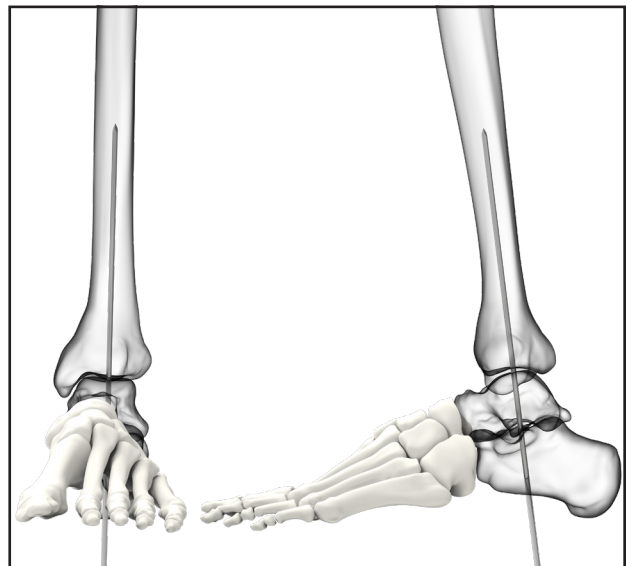

ALTERNATIVE: FREEHAND STARTER WIRE INSERTION

1. A plantar incision is made just distal to the plantar fat pad, slightly lateral to midline. Blunt dissection is carried down to the plantar calcaneus to avoid disruption of nearby neurovascular bundles. The tip of the 3.2mm Starter Wire is placed against the plantar aspect of the calcaneus.

Tip: A lateral fluoroscopic image may be utilized to confirm correct distal to proximal trajectory of the Starter Wire.

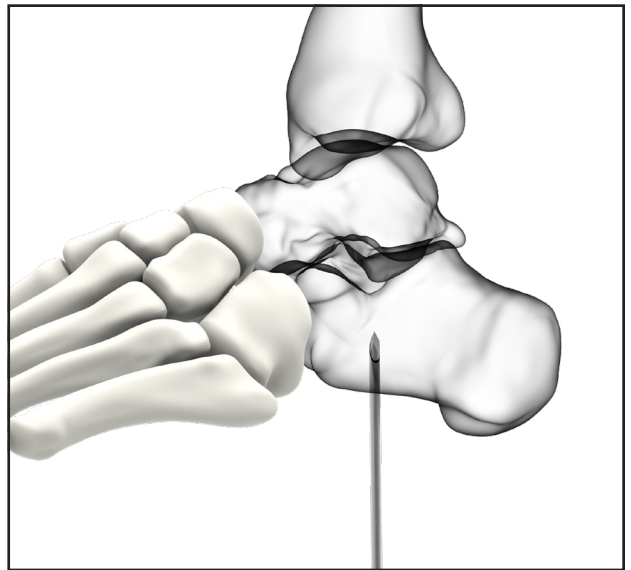

2. Once the correct starting point is confirmed on lateral fluoroscopy, advance the 3.2mm Starter Wire through the calcaneus, talus, and into the tibia, using AP, lateral, and calcaneal axial fluoroscopic views throughout the process. Ensure that the Starter Wire remains centered within the calcaneus, talus, and tibia, terminating in the tibial medullary canal.

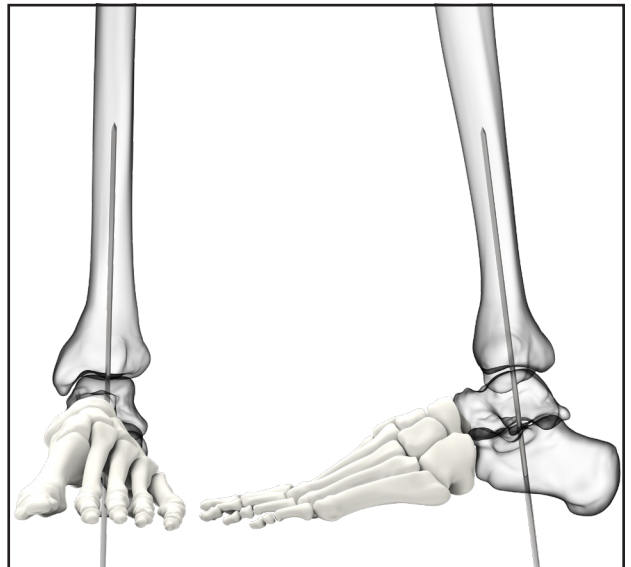

ENTRY REAMING

1. An extension of the plantar incision may be made such that the plantar incision measures 3-4cm. Perform blunt dissection to the plantar surface of the calcaneus as needed.

2. Insert the 8.0mm Primary Reamer over the 3.2mm Starter Wire. Advance it proximally over the wire through the sole of the foot, reaming through the subtalar and tibiotalar surfaces, into the tibia. Drill past the metaphyseal flare of the tibia.

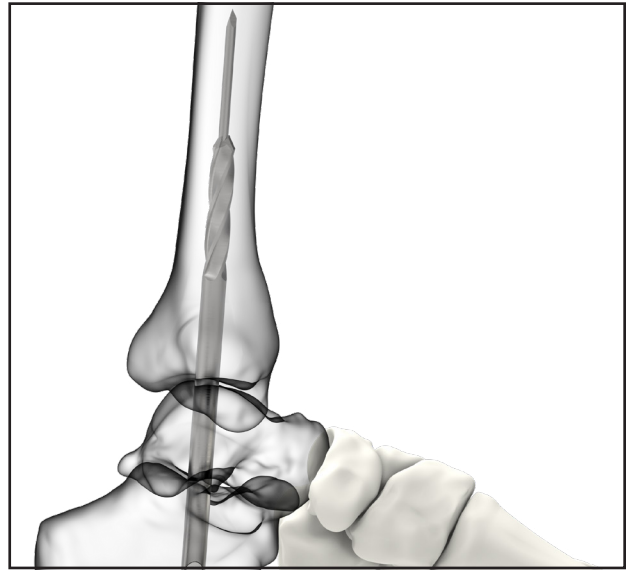

3. Insert the 13.5mm Secondary Reamer over the Starter Wire. Ream proximally until the laser mark on the Secondary Reamer is subflush with the plantar cortex of the calcaneus.

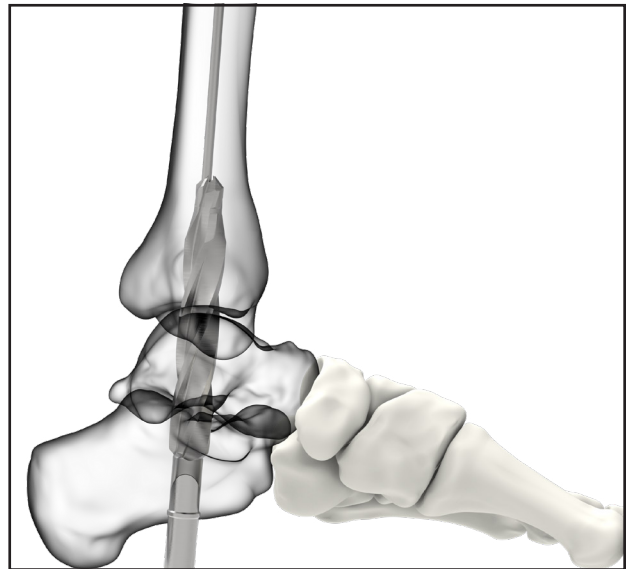

Tip: It is recommended to check lateral fluoroscopy to ensure that the larger 13.5mm diameter contacts the metaphyseal bone of the tibia and that the proximal portion of the reamer matches the intended countersink of the Nail.

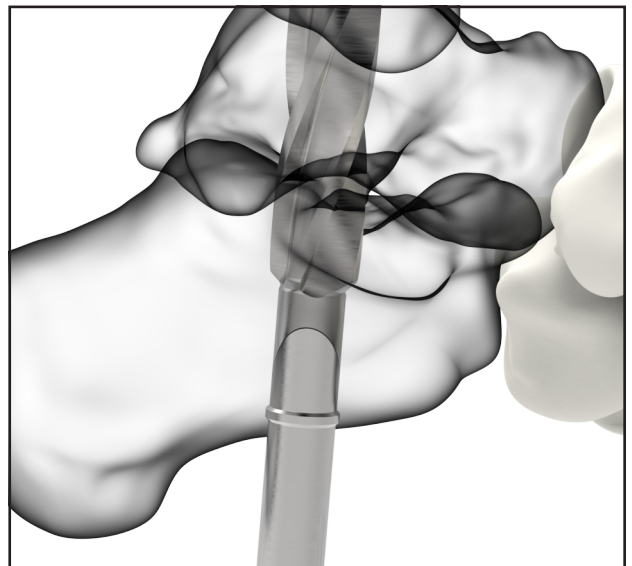

FLEXIBLE REAMING

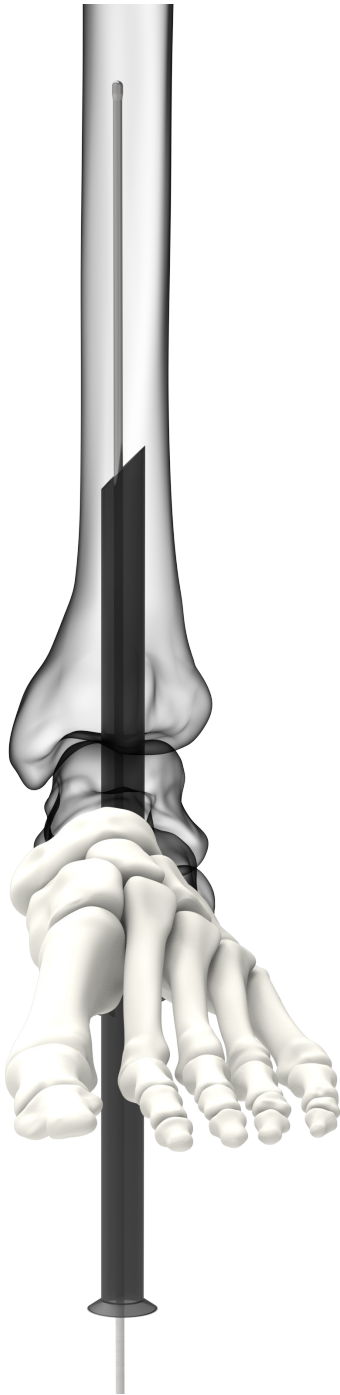

1. After completing primary and secondary reaming, insert the Exchange Tube 6mm over the Starter Wire. Then, from the plantar aspect of the calcaneus, replace the Starter Wire with the Olive Reaming Rod, advancing it into the distal tibia. Confirm the position and length of the Olive Reaming Rod using fluoroscopic imaging.

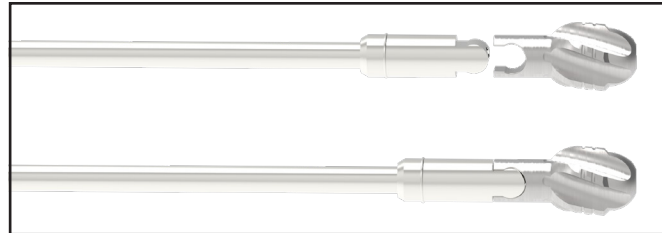

2. Attach the desired Reamer Head to the Reamer Shaft, thus creating a Reamer Construct. It is recommended to begin with the smallest diameter Reamer Head (10.0mm).

3. Using the Reamer Construct, perform incremental reaming over the Olive Reaming Rod, gradually increasing the diameter of the Reamer Head in 0.5mm increments until the desired diameter is achieved, while continuously confirming progress under fluoroscopy. It is recommended to oversize the final reamer diameter by 1.0mm relative to the chosen Nail diameter.

Tip: Ensure the forward gear is selected for all reaming operations - even when withdrawing the reamer.

4. The Olive Tipped Reaming Rod can remain in place after modular reaming, as the nail can be inserted over it—the olive tip's diameter is smaller than the nail's core diameter.

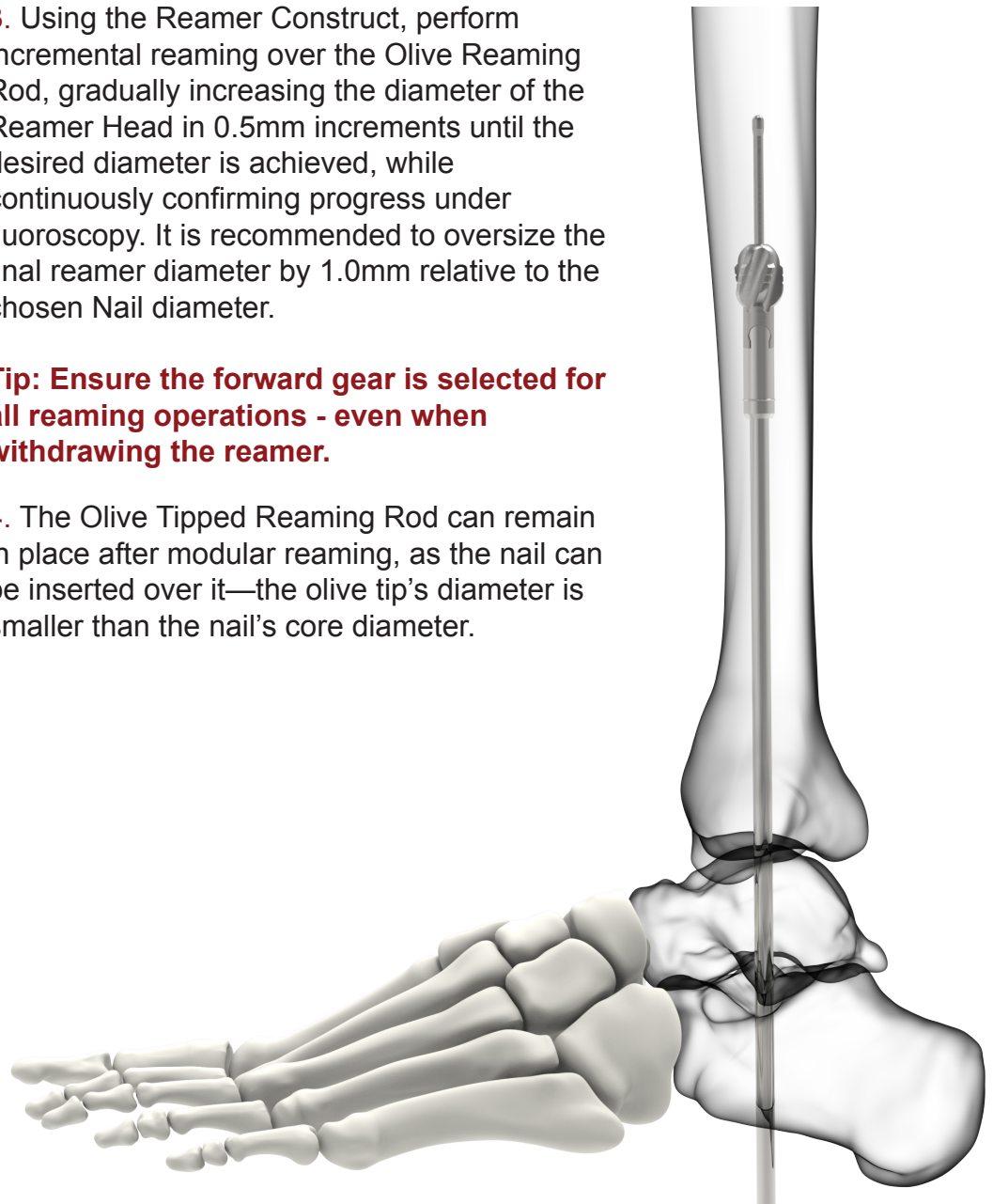

NAIL SELECTION

1. From the preoperative planning and intraoperative assessment, the appropriate nail size should have been selected.
2. The proximal end of the nail should ideally be at least 50mm past any potential stress risers, including fractures, non-union sites, bone resection locations and pre-existing screw holes.

Tip: Selecting a nail 1.0mm less than the diameter reamed is suggested to reduce the need for excessive impaction during nail insertion and the consequent risk of fracture.

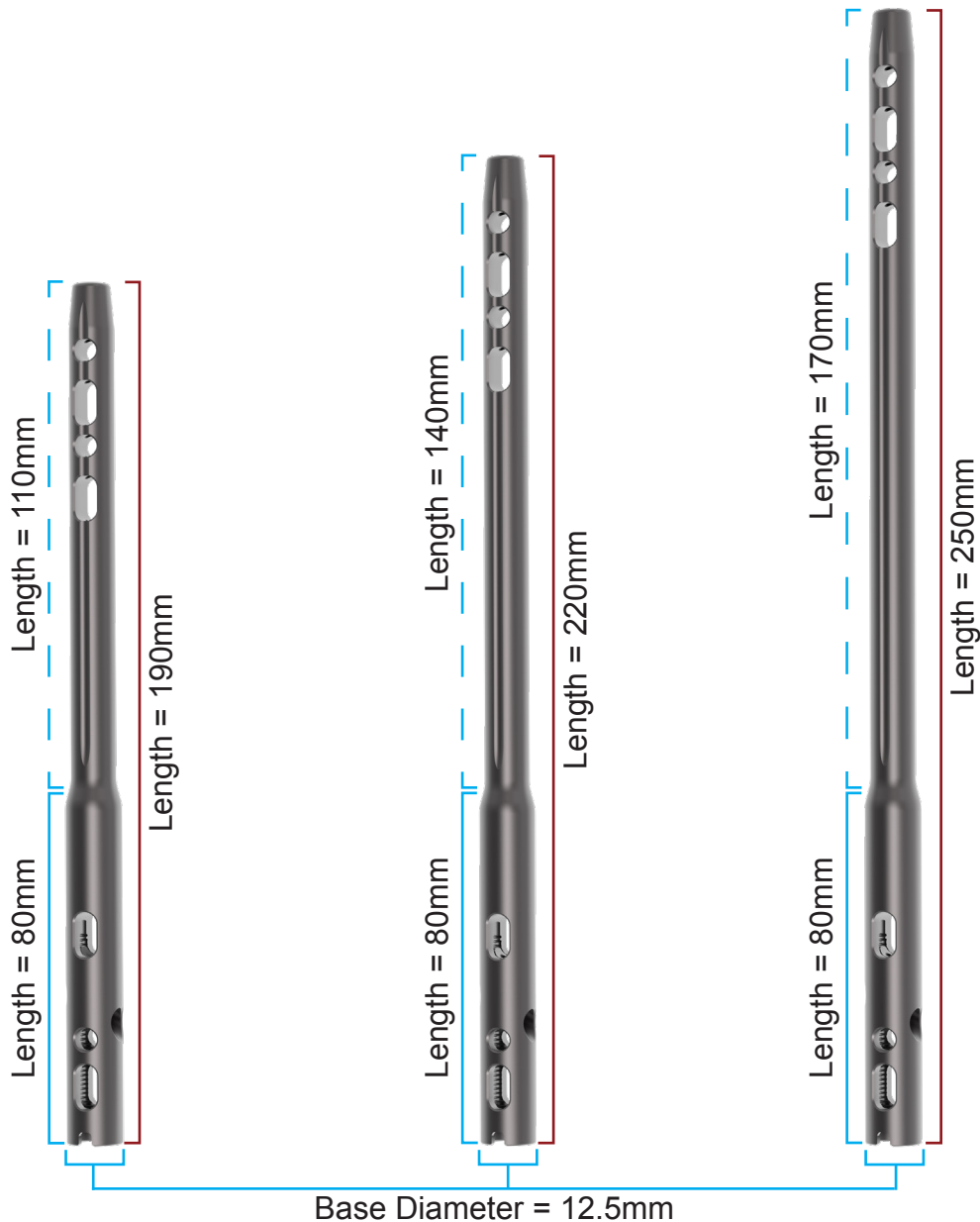

		LENGTH		
		190mm	220mm	250mm
PROXIMAL DIAMETER	10.0mm	●	●	●
	11.0mm	●	●	●
	12.0mm	●	●	●

OUTRIGGER ASSEMBLY

1. Locate the Slotted Stage (a) and insert it into the Outrigger (b).

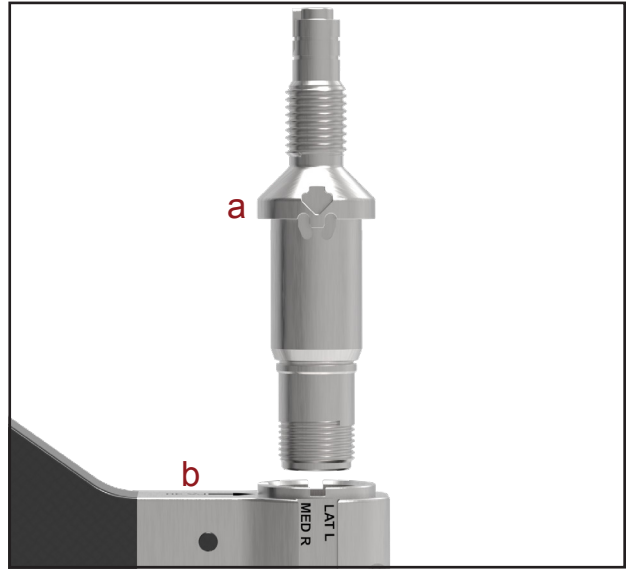

2. Align the arrow on the Slotted Stage with any groove on the Outrigger. Final alignment will be determined in the following steps.

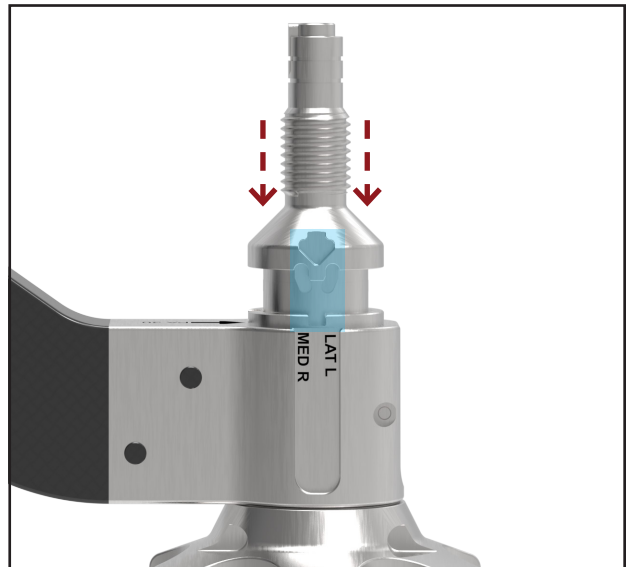

3. Once the desired alignment of the arrow with the groove is achieved, rotate the wheel at the base of the Outrigger until the Slotted Stage is fully seated.

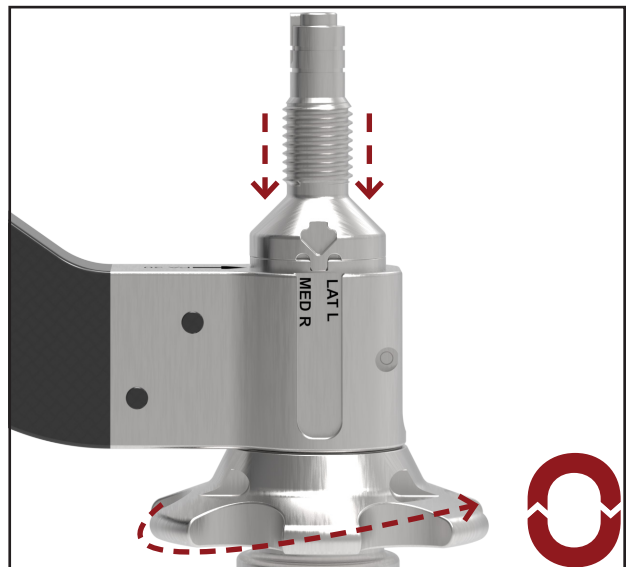

OUTRIGGER ASSEMBLY

1. Locate the Draw Bolt Socket Adapter and attach to a provided Ratcheting Handle.
2. Locate the Slotted Stage and insert into the Outrigger.
3. Locate the External Compressor and thread on to the Slotted Stage.

Tip: Take care not to over-tighten the External Compressor to the Slotted Stage

4. Align the notch on the chosen Nail to the notch located on the stage of the Outrigger.
5. Locate the Nail Draw Bolt and attach to the Draw Bolt Socket Adapter.

Tip: Handle with care to prevent dropping the Nail Draw Bolt.

6. Insert the Draw Bolt Assembly into the base of the Outrigger and engage the base of the Nail.
7. Once engaged, rotate the ratcheting handle clockwise until Nail is secure on the Outrigger.

Precaution: Insufficiently tightened components may result in misalignments.

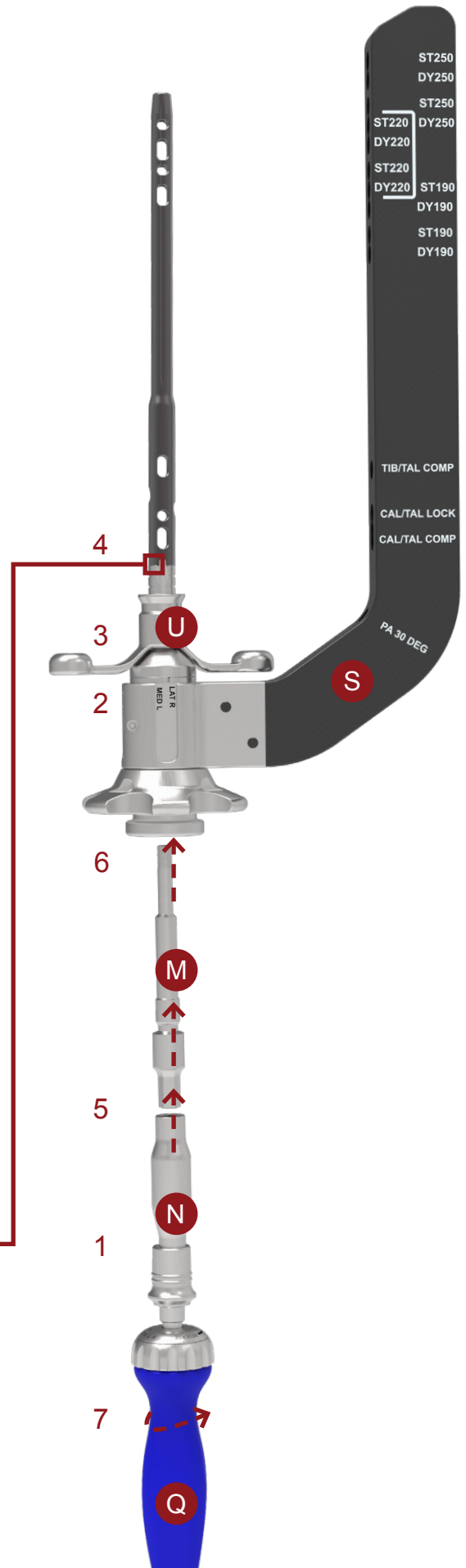

The circled letters correspond to the labeled tray layout shown on pages 50-51.

OUTRIGGER LABELLING

250mm Nail *M/L Position*
 Static Hole Option #1
 Dynamic Hole Option #1
 Static Hole Option #2
 Dynamic Hole Option #2

220mm Nail *M/L Position*
 Static Hole Option #1
 Dynamic Hole Option #1
 Static Hole Option #2
 Dynamic Hole Option #2

190mm Nail *M/L Position*
 Static Hole Option #1
 Dynamic Hole Option #1
 Static Hole Option #2
 Dynamic Hole Option #2

All Nails *L/M Position*
 "Stage 1"
 Tibia to Talus Dynamic
 Compression

All Nails *L/M Position*
 "Stage 2"
 Tibia to Talus Static
 Fixation

All Nails *L/M Position*
 "Stage 2"
 Tibia to Talus Dynamic
 Compression

All Nails *P/A Position*
 30° Bicortical P/A Screw

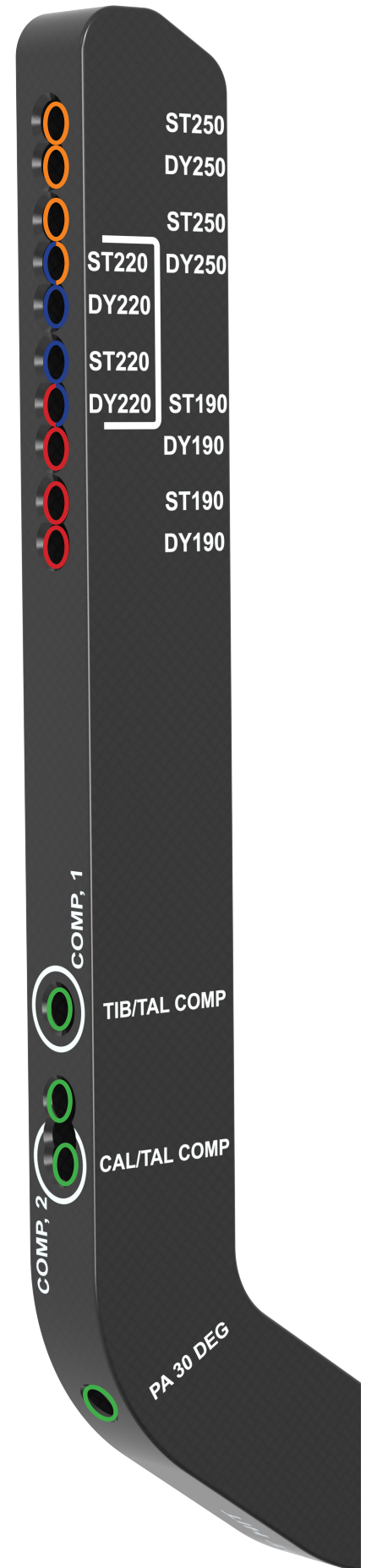

Tip: Physical Outrigger is not color-coded.

OUTRIGGER ROTATION

1. When the Outrigger is positioned at the “PA 30” orientation during insertion, it serves as a neutral reference point, as the P/A angle is consistent for both the left and right legs.

Tip: The arrow on the Outrigger indicates the orientation of the Nail within the leg.

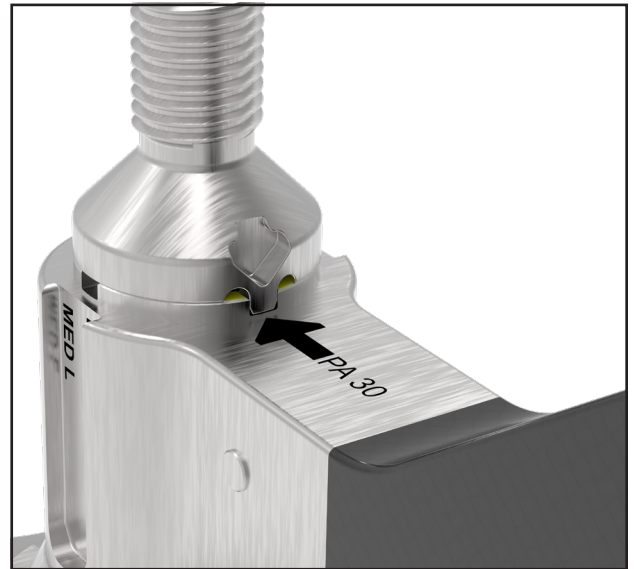

2. When rotating the Nail medially for proximal tibial screw insertion, the arrow on the Outrigger will align with “LAT R / MED L” or “LAT L / MED R” depending on whether the procedure is being performed on the right or left leg.



3. When rotating the Nail laterally for talus and calcaneal screw insertion, the arrow on the Outrigger will indicate opposite position from that observed during medial rotation. For example, if the arrow aligned with “LAT R / MED L” during medial screw insertion, it will point to “LAT L / MED R” during lateral screw insertion.

If the Nail does not fully seat onto the Outrigger, it may not be properly aligned or fully engaged in the correct position.



OUTRIGGER ALIGNMENT CHECK



1. Locate the Guide Tube and the 5mm Drill Guide and attach by screwing together. Insert Drill Guide construct into both proximal dynamic or static holes for the chosen nail, in the *medial / lateral position*.

2. Insert the 4/5mm M/L Drill Short 20-70mm Scale into the most proximal Drill Guide construct, followed by the 4/5mm M/L Drill Long 20-70mm Scale into the next most proximal Drill Guide construct. Verify that both drills pass smoothly through the corresponding holes in the Nail.

Tip: This system uses two drill bit lengths to achieve rotational stability through the most proximal screw hole with the short drill bit, while the longer drill bit is used to place the next proximal screw without risking hand interference.

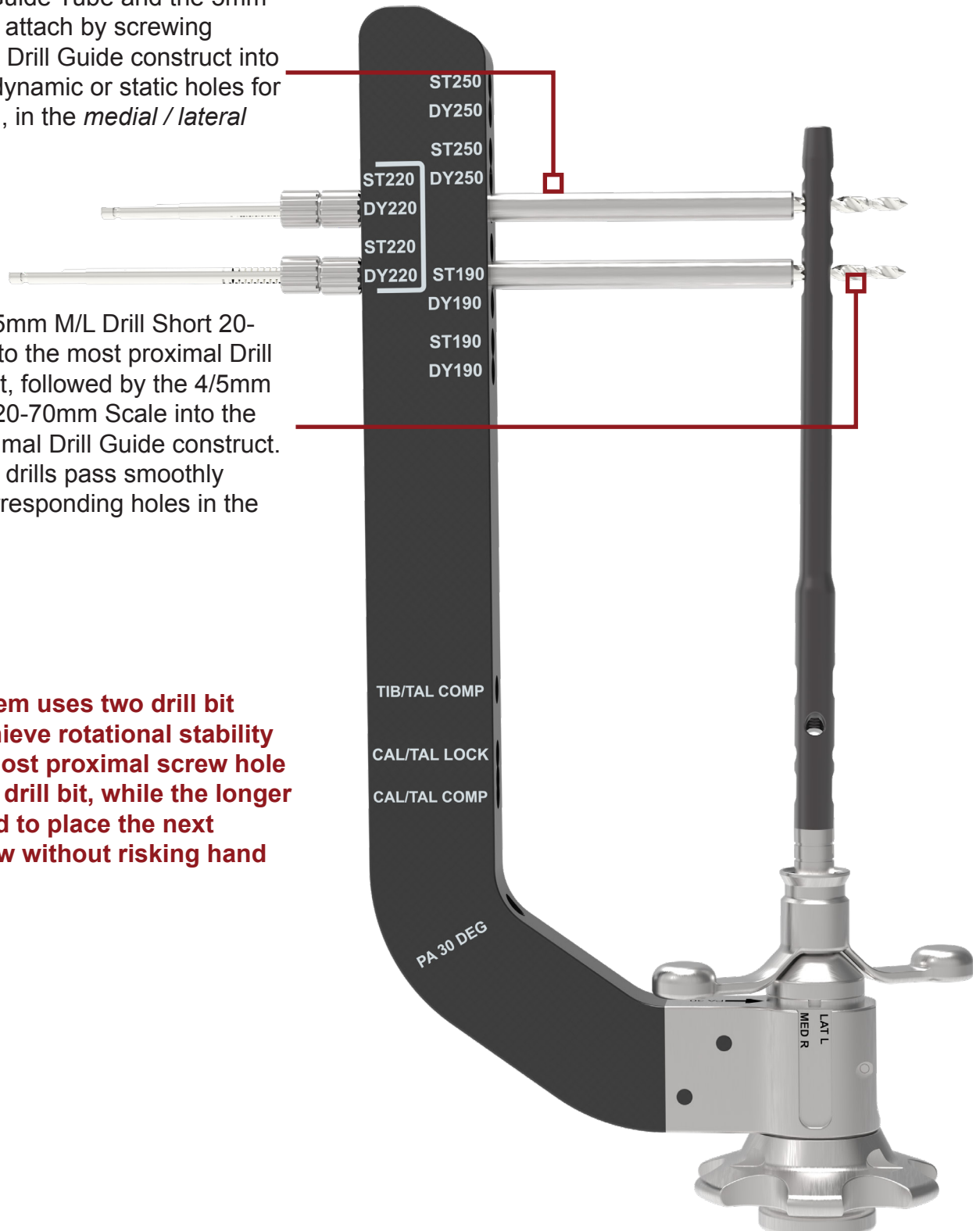

OUTRIGGER ALIGNMENT CHECK



3. Loosen the locking wheel and rotate the Outrigger arm to the *posterior* position.

4. Locate the Guide Tube and the P/A Drill Guide and attach by screwing together. Insert Drill Guide construct into the "PA 30 DEG" hole in the outrigger.

5. Insert the P/A Step Drill into the Drill Guide Construct. Verify that the Drill passes smoothly through the "PA 30 DEG" hole in the Nail.

Tip: To move the Outrigger arm around the axis of the nail, simply loosen the wheel located at the bottom of the Outrigger. Once the desired M/L or P/A trajectory is achieved, lock the wheel back into place.

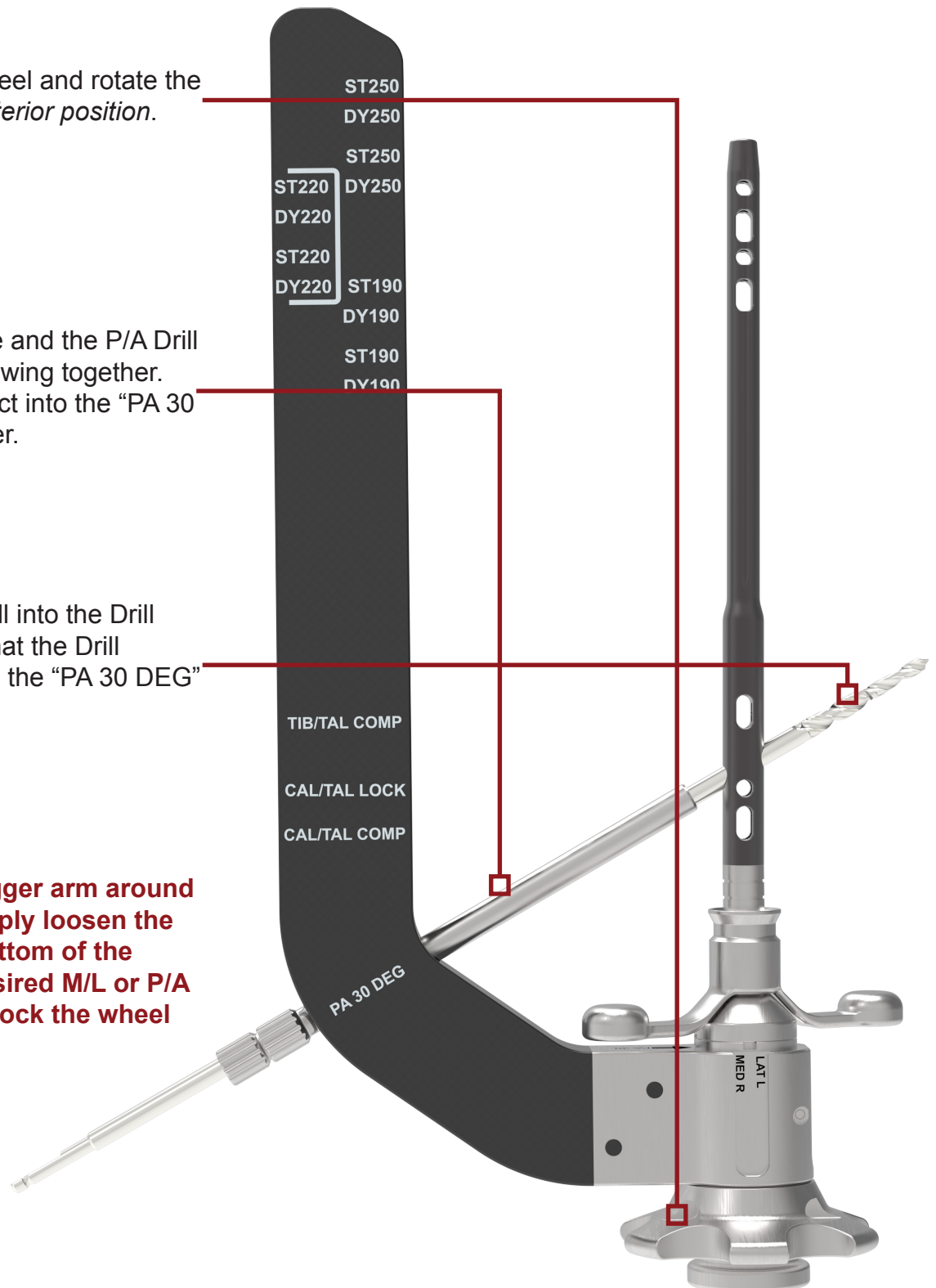

GOLD CLIP REMOVAL

1. The gold clip is designed to secure the internal compression cradle used in Stage 1, preventing migration during transit.

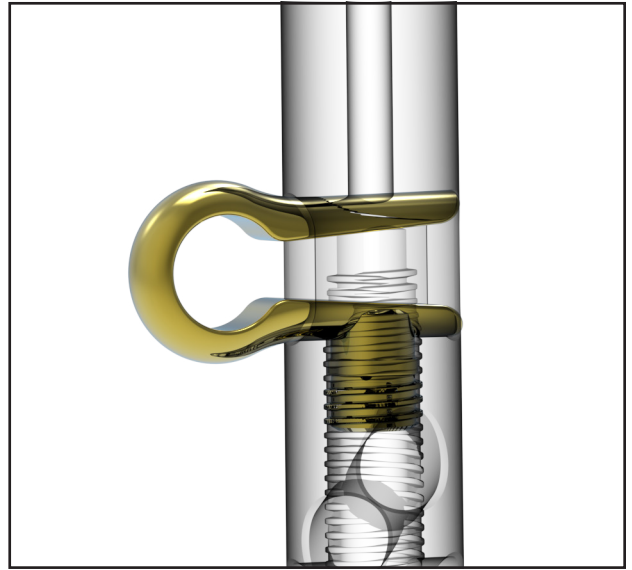

2. To remove the gold clip from the nail prior to insertion, gently squeeze both sides of the clip to decompress and disengage it from the nail body.

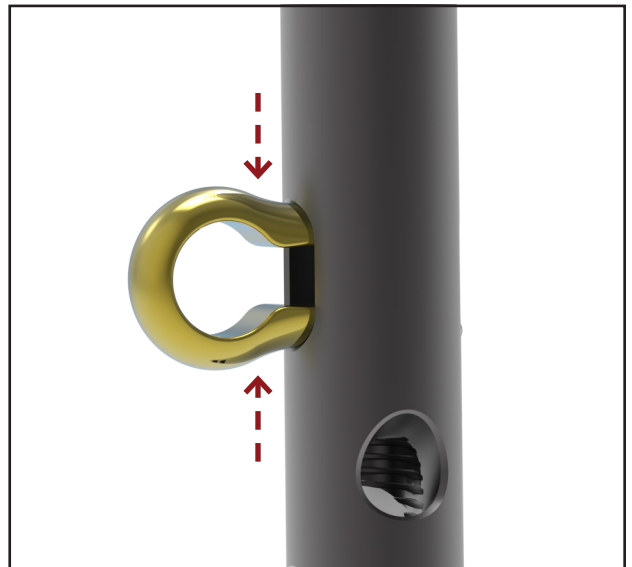

3. Once the clip has been disengaged from the nail, remove it completely and discard appropriately.

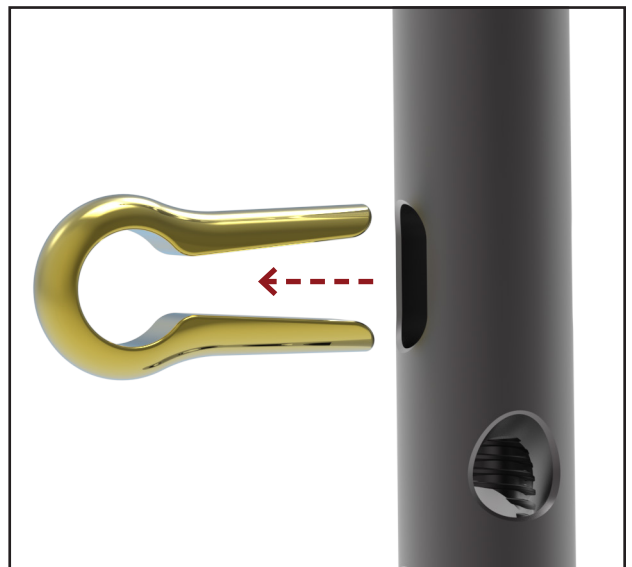

NAIL INSERTION

Precaution: The Gold Clip must be removed prior to Nail insertion.

1. Three key position checks are essential to confirm proper Nail placement before inserting screws: **Superior/Inferior Insertion Depth** and **Nail Rotation**.

SUPERIOR/INFERIOR INSERTION DEPTH

2. Ensure that the Exchange Tube has been removed from the tibial canal, then insert the Nail and attached Outrigger into the reamed canal, over the Olive Tipped Reaming Rod. The Nail can be advanced manually over the Olive Tipped Reaming Rod with gentle rotational movements and forward pressure.

3. If impaction is deemed necessary, slide the Impactor over the Reaming Rod onto the base of the Outrigger Assembly, being careful to ensure the Olive Tipped Reaming Rod is kept in place. Gentle impaction with a mallet against the impactor may then be used.

Tip: The Carbon Fiber Outrigger arm, Locking Wheel, and Nail Draw Bolt should never be hammered. Vigorous hammering should always be avoided. You will only need to hammer if reaming has been inadequate.

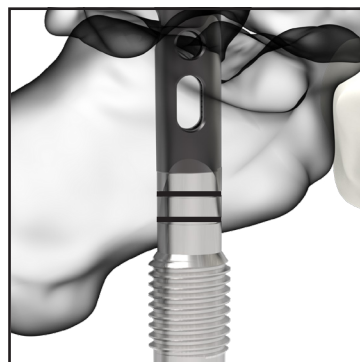
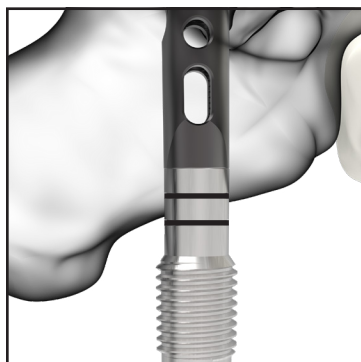

Insertion Depth
Fluoroscopic Marker

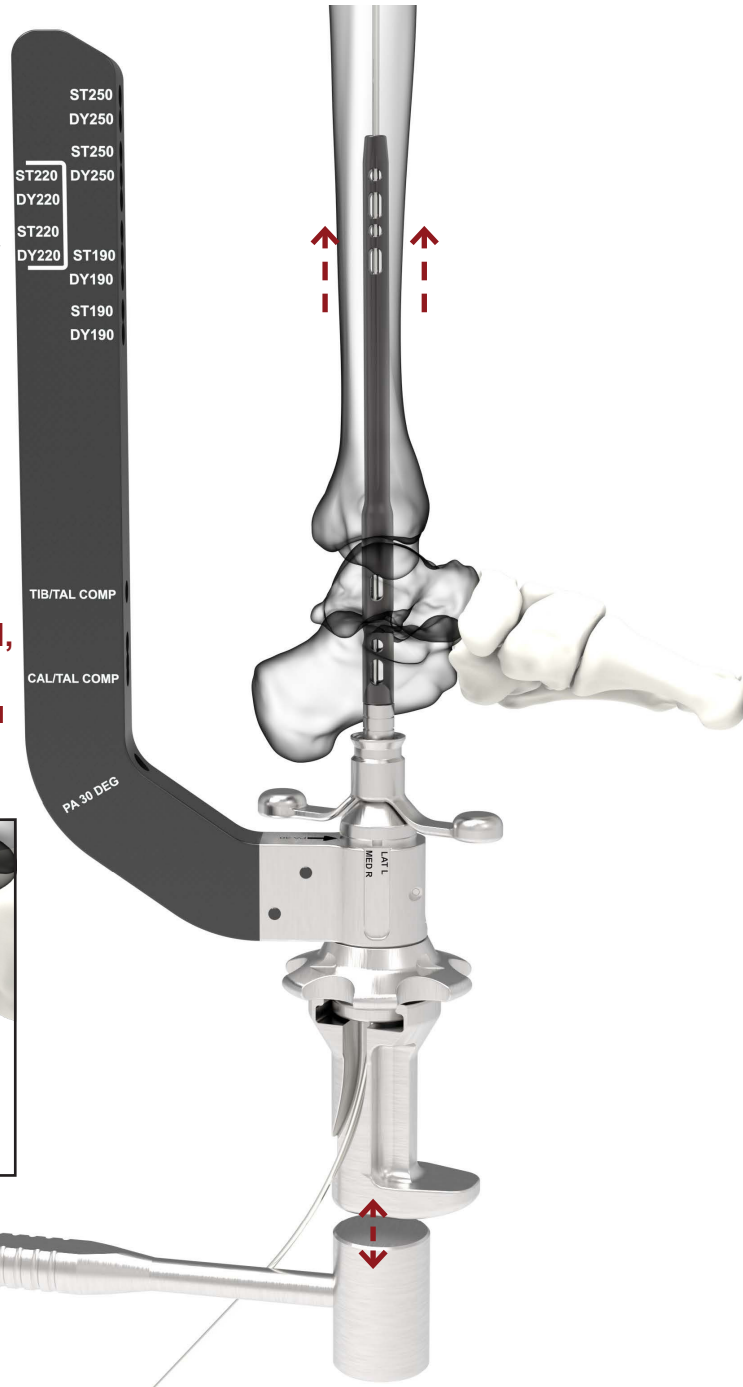

4. The Nail should be inserted so that its end is recessed between 5mm (first line) and 10mm (second line) within the calcaneus.

Tip: If a mallet is used to insert the Nail, it is recommended to insert the Draw Bolt adapter and ensure no loosening occurs between the Draw Bolt and the Nail.

NAIL INSERTION



NAIL ROTATION

1. With the Outrigger positioned posteriorly, insert the PA Drill Guide construct into the “PA 30 DEG” hole on the Outrigger. Assess the alignment of the Drill Guide in relation to the calcaneus. The optimal position is centered on the tuberosity and aligned with the talar neck in lateral fluoroscopic view. Confirm that the trajectory is directed toward the center of the talar neck on both lateral and axial fluoroscopic views.

IDEAL POSITION - INFERIOR VIEW

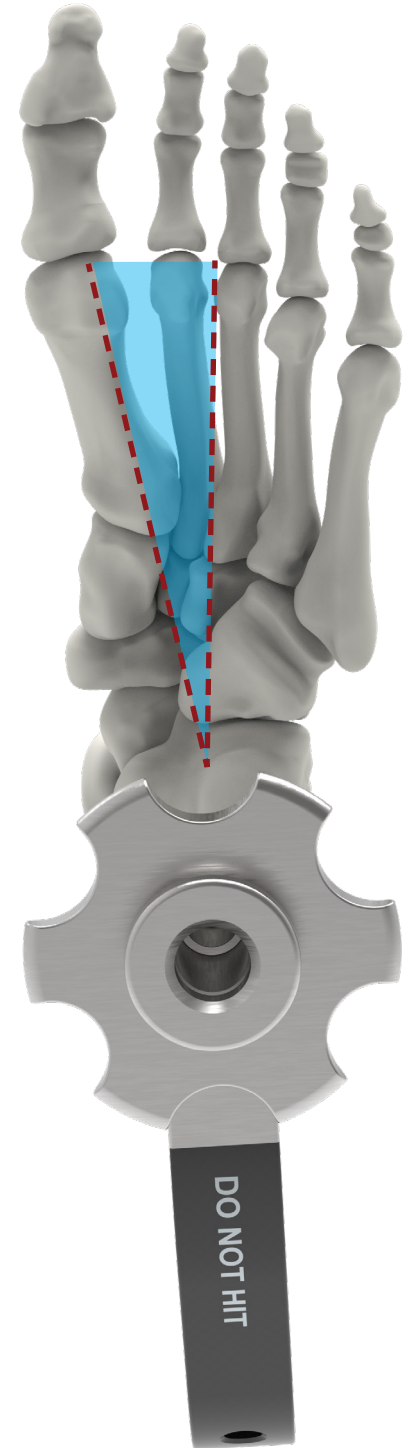
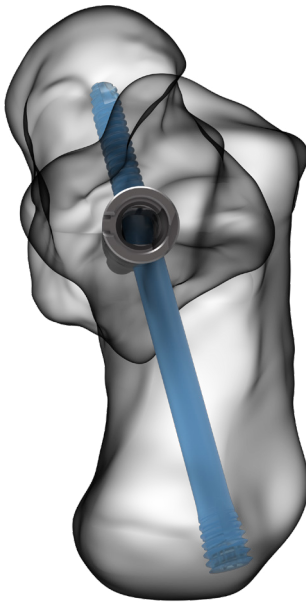

Tip: Nail rotation is vital to ensure quality talus purchase for the PA Screw .

Tip: Once the Nail has been fully inserted, remove the Olive Tipped Reaming Rod from the Nail before drilling for the first screw.

GENERAL INSTRUMENTATION GUIDANCE

Trocar

The Trocar can be used prior to drilling any screws to confirm accurate positioning on the near cortex. To use, insert it into the Drill Guide Construct and gently tap it with a mallet. To remove, simply pull it out of the construct.



Drilling

Proceed carefully when drilling through the far cortex of the bone, as plunging the Drill bit - due to its gradually increasing diameter - may compromise screw purchase in the far cortex of the tibia.



Screw Measurement

Whether measuring screw depth using the Solid Depth Gauge or the Drill bit, ensure that the Drill Guide is firmly against the bone and that the Depth Gauge or Drill bit is securely engaging the lateral or medial cortex of the bone.



Screw Insertion

Resistance will increase slightly as the tapered head engages near cortex of the bone.

Precaution: Ensure the screw is fully seated before disengaging the driver.



Stage 1 & Stage 2 Compression

Precaution: Manual application is recommended over power tools when applying internal compression to prevent potential damage or loss of control.



PROXIMAL TIBIAL SCREW INSERTION

Precaution: Confirm that the Reaming Rod is removed from the Nail before drilling to prevent clashes.

1. Rotate the Outrigger to the *medial position* for the operative side (R/L). Confirm that the Drill Guide construct is aligned for the intended configuration (static or dynamic). Make a small stab incision at the proximal Drill Guide site, then perform blunt dissection and position the Drill Guide to abut the bone. Drill bicortically from medial to lateral through the Drill Guide using the 4/5mm M/L Drill Short 20-70mm Scale in the tibia. Leave the Drill in place, then proceed to the second screw and repeat the process using the 4/5mm M/L Drill Long 20-70mm Scale.

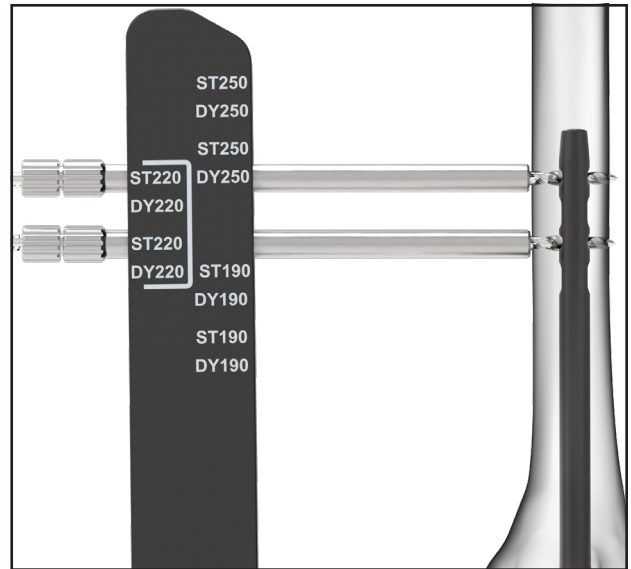

2. 5mm Screw depth can be measured from the Drill with the Drill Guide in place and/or using the SUCCESSION Depth Gauge 20-120mm after removal of the 5mm Drill Guide.

Note: A Countersink is available, when needed, to facilitate seating of M/L screws in dense bone. It is intended for use only through the Guide Tube and must not be operated under power.

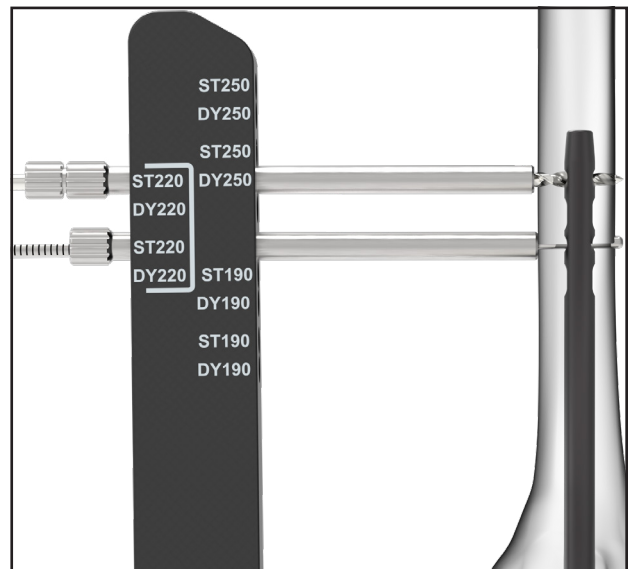

3. Once the 5mm Drill Guide is removed, insert the appropriately sized 5mm Screw through the Guide Tube and into the Nail using the Retaining Screwdriver and handle, turning in a clockwise direction until the laser mark on the Driver meets the end of the Guide Tube, or when the head of the 5mm Screw is snug against the tibia.

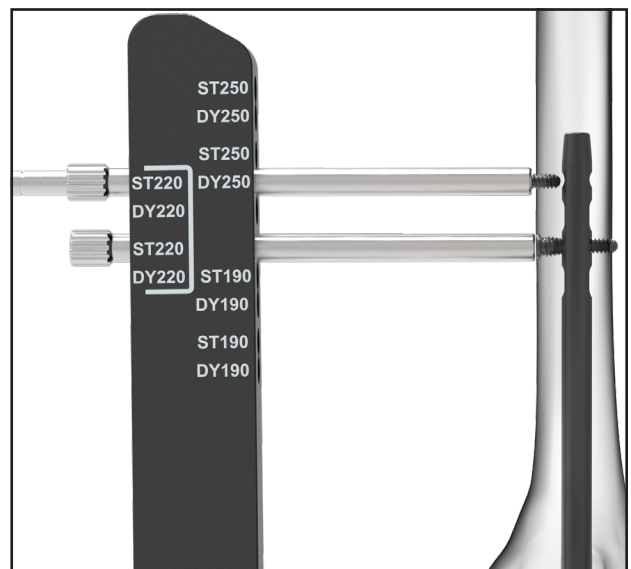

4. Verify the 5mm Screw length and placement under fluoroscopy. Repeat the steps above to place the second 5mm Screw.

StageLock® COMPRESSION OPTIONS:

Option 1	Full Internal Compression	Pages 28 - 32
Option 2	Hybrid Internal Compression	Pages 33 - 35
Option 3	Full External or No Compression	Pages 36 - 37

StageLock® Technology

StageLock® Technology in the SUCCESSION® TTC Nail System enables internal, independent, and controlled compression across both the ankle and subtalar joints. This dual-joint compression capability allows surgeons to apply targeted compression at each fusion interface separately, optimizing compression without compromising stability. By delivering controlled, staged engagement, StageLock® is designed to support construct stability and accommodate anatomical variation, helping surgeons address the demands of complex hindfoot reconstructions.

Option 1 (Full Internal Compression)

Provides independently controlled internal compression (0-5mm) at the tibiotalar joint by mechanically advancing the lateral/medial screw within the talus toward the tibia using a threaded cradle. Additionally, StageLock® allows for 0-5mm of internal compression at the subtalar joint by advancing the screw within the calcaneus toward the talus and securing the compression with a secondary screw placed proximally.

Option 2 (Hybrid Internal Compression)

Allows for the application of external compression (0-18mm) to the subtalar joint following internal independently controlled compression of the tibiotalar joint (Stage 1 - 0-5mm).

Option 3 (Full External or No Compression)

Depending on the patient's needs, this approach allows for either full external compression (0-18mm) across both the tibiotalar and subtalar joints - stabilized with lateral/medial screws in the talus and calcaneus - or no compression at all, with stabilization achieved using the same screw configuration.



When this symbol appears, it signifies clockwise rotation.



When this symbol appears, it signifies counterclockwise rotation.

DYNAMIC TALUS SCREW INSERTION (Stage 1)

1. Rotate the Outrigger to the *lateral position* for the operative side (R/L). Confirm that the Drill Guide Construct is aligned in the “TIB/TAL COMP” hole in the Outrigger. Make a small stab incision at the proximal Drill Guide site, then perform blunt dissection and position the Drill Guide to abut the bone. Drill bicortically from lateral to medial through the Drill Guide using the 4/5mm M/L Drill (Long or Short) 20-70mm Scale in the talus.

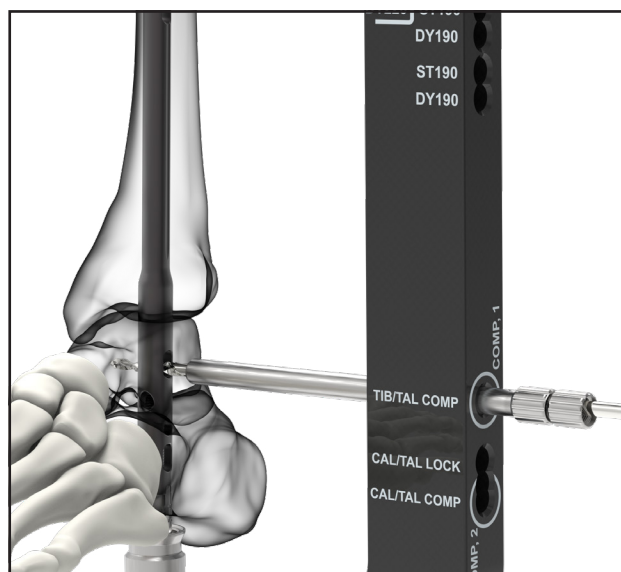

2. 5mm Screw depth can be measured from the Drill with the Drill Guide in place and/or using the SUCCESSION Depth Gauge 20-120mm after removal of the 5mm Drill Guide.

Note: A Countersink is available, when needed, to facilitate seating of M/L screws in dense bone. It is intended for use only through the Guide Tube and must not be operated under power.

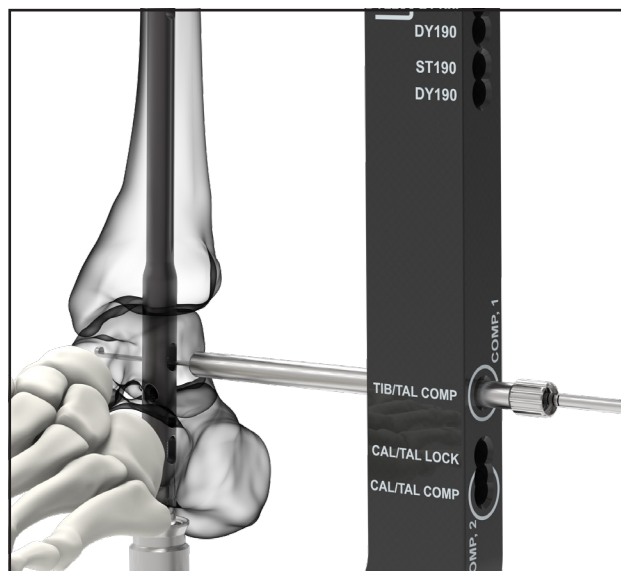

3. Once the 5mm Drill Guide is removed from the Guide Tube, insert the appropriately sized 5mm Screw through the Guide Tube and into the Nail using the Retaining Screwdriver and handle, turning in a clockwise direction until the laser mark on the Driver meets the end of the Guide Tube, or when the head of the 5mm Screw is snug against the talus.

4. Verify the 5mm Screw length and placement under fluoroscopy.

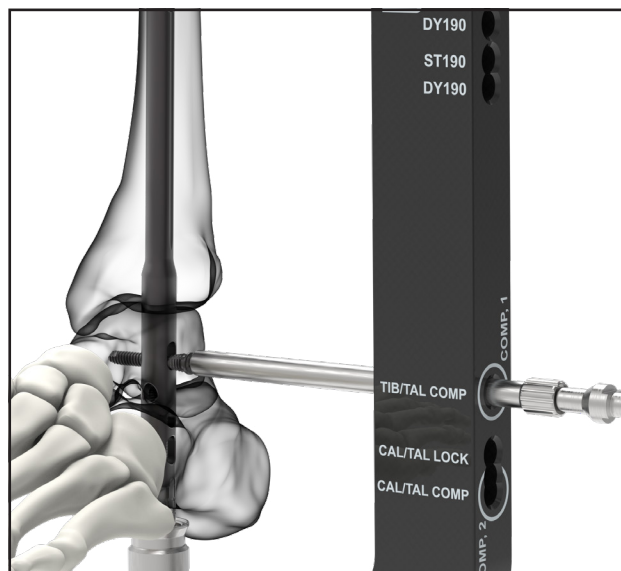

Stage 1 Driver



DYNAMIC TALUS SCREW INSERTION (Stage 1)

5. Locate the Stage 1 Driver and attach to a Ratcheting Handle. Insert the Stage 1 Driver into the base of the Outrigger and into the Nail base. Once interference is achieved with the cradle, rotate clockwise, mechanically compressing the talus to the tibia.

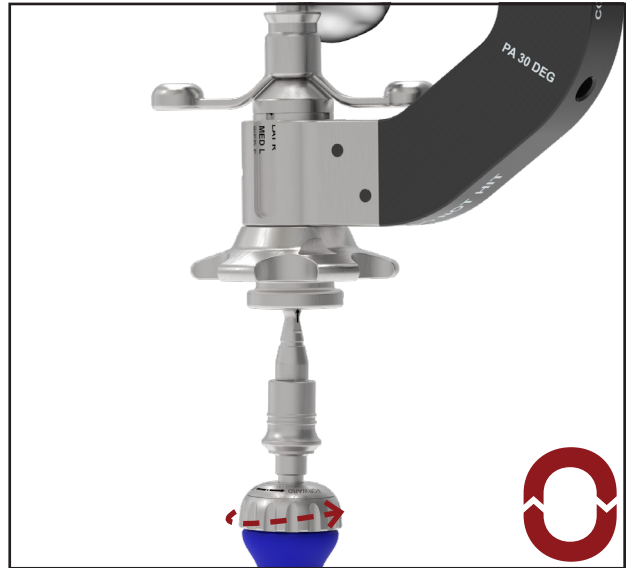

6. Up to 5mm of internal compression is offered at Stage 1 (TIB/TAL). Check fluoroscopy and remove the Stage 1 Driver once adequate compression has been attained.

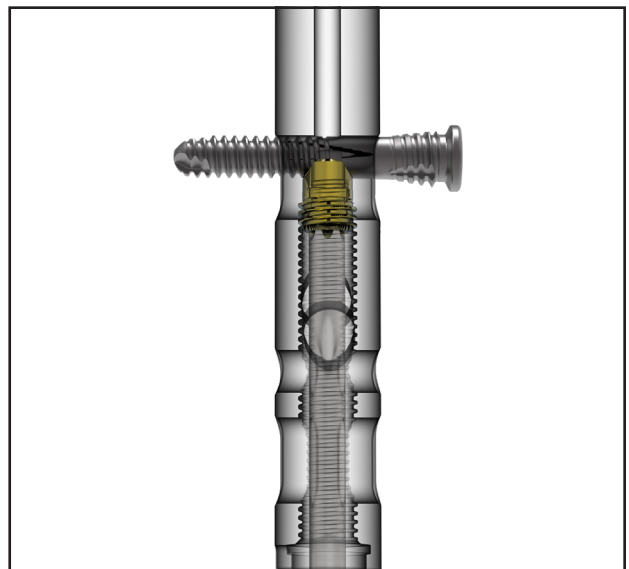

DYNAMIC CALCANEUS SCREW INSERTION (Stage 2)

1. Keep the Outrigger in the *lateral position* for the operative side (R/L). Confirm that the Drill Guide Construct is aligned in the “CAL/TAL COMP” hole in the Outrigger. Make a small stab incision at the proximal Drill Guide site, then perform blunt dissection and position the Drill Guide to abut the bone. Drill bicortically from lateral to medial through the Drill Guide using the 4/5mm M/L Drill (Long or Short) 20-70mm Scale in the calcaneus.

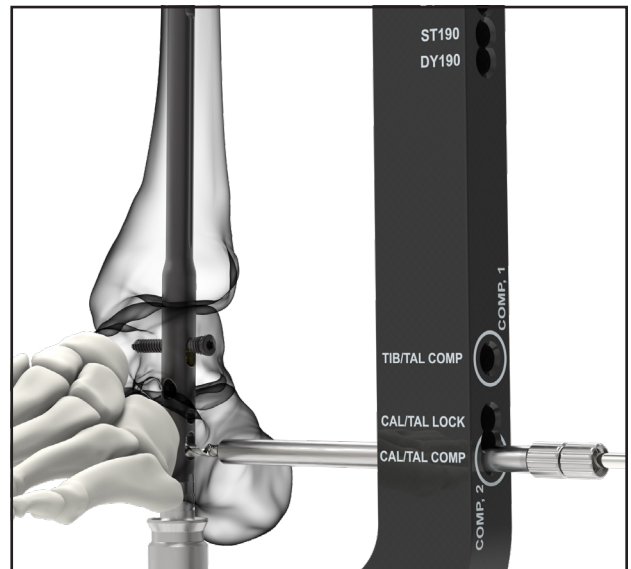

2. 5mm Screw depth can be measured from the Drill with the Drill Guide in place and/or using the SUCCESSION Depth Gauge 20-120mm after removal of the 5mm Drill Guide.

Note: A Countersink is available, when needed, to facilitate seating of M/L screws in dense bone. It is intended for use only through the Guide Tube and must not be operated under power.

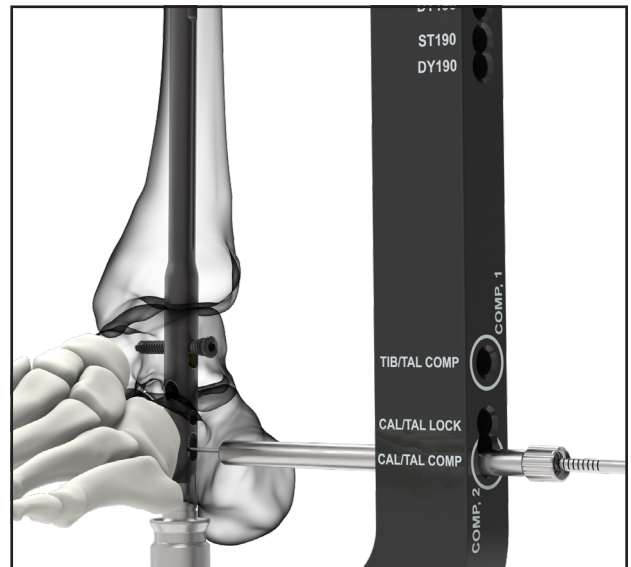

3. Once the 5mm Drill Guide is removed, insert the appropriately sized 5mm Screw through the Guide Tube and into the Nail using the Retaining Screwdriver and handle, turning in a clockwise direction until the laser mark on the Driver meets the end of the Guide Tube, or when the head of the 5mm Screw is snug against the calcaneus.

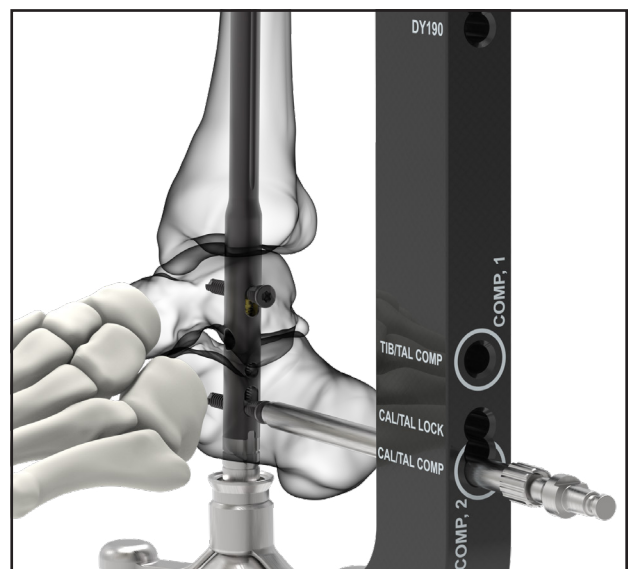

Stage 2 Driver



DYNAMIC CALCANEUS SCREW INSERTION (Stage 2)

4. Locate the Stage 2 Driver and attach to a Ratcheting Handle. Insert the Stage 2 Driver into the base of the Outrigger and into the Nail base. Once interference is achieved with the internal threading, rotate clockwise, mechanically compressing the calcaneus to the talus.

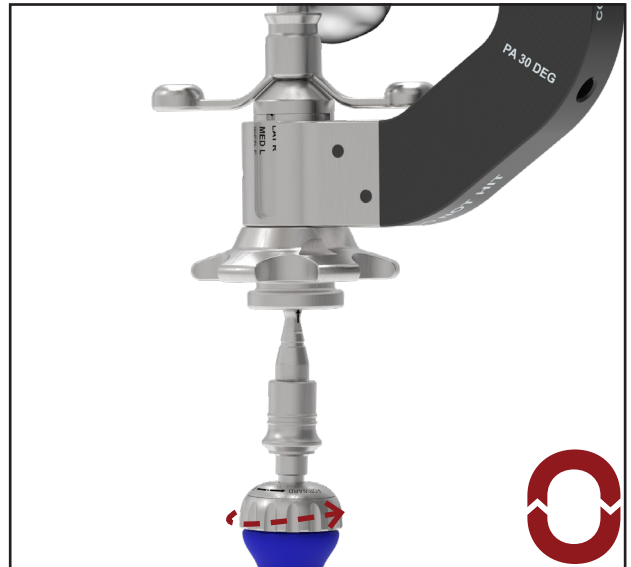

5. Up to 5mm of internal compression is offered at Stage 2 (CAL/TAL). Check fluoroscopy once adequate compression has been attained.

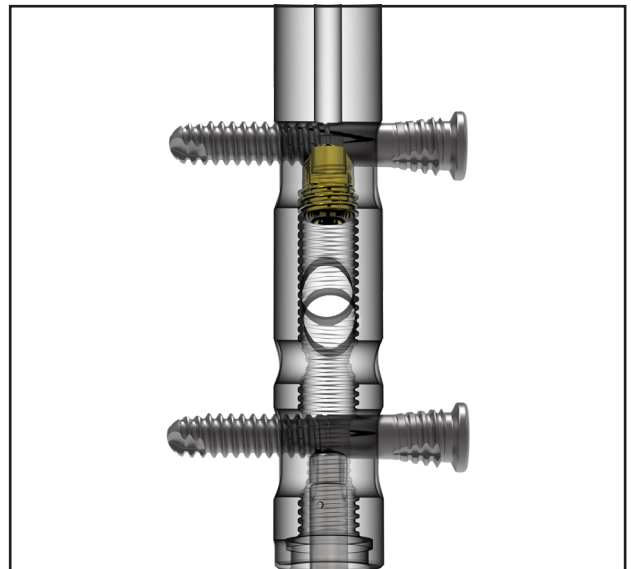

DO NOT REMOVE THE STAGE 2 DRIVER FROM BASE OF NAIL - WAIT UNTIL THE NEXT STEP HAS BEEN COMPLETED

LOCKING CALCANEUS SCREW INSERTION

1. Keep the Outrigger in the *lateral position* for the operative side (R/L). Confirm that the Drill Guide Construct is aligned in the “CAL/TAL LOCK” hole in the Outrigger. Make a small stab incision at the proximal Drill Guide site, then perform blunt dissection and position the Drill Guide to abut the bone. Drill bicortically from lateral to medial through the Drill Guide using the 4/5mm M/L Drill (Long or Short) 20-70mm Scale in the calcaneus.

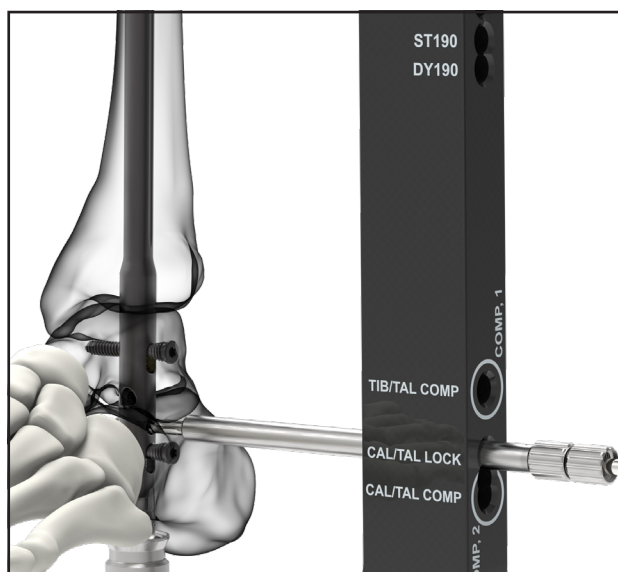

2. 5mm Screw depth can be measured from the Drill with the Drill Guide in place and/or using the SUCCESSION Depth Gauge 20-120mm after removal of the 5mm Drill Guide.

Note: A Countersink is available, when needed, to facilitate seating of M/L screws in dense bone. It is intended for use only through the Guide Tube and must not be operated under power.

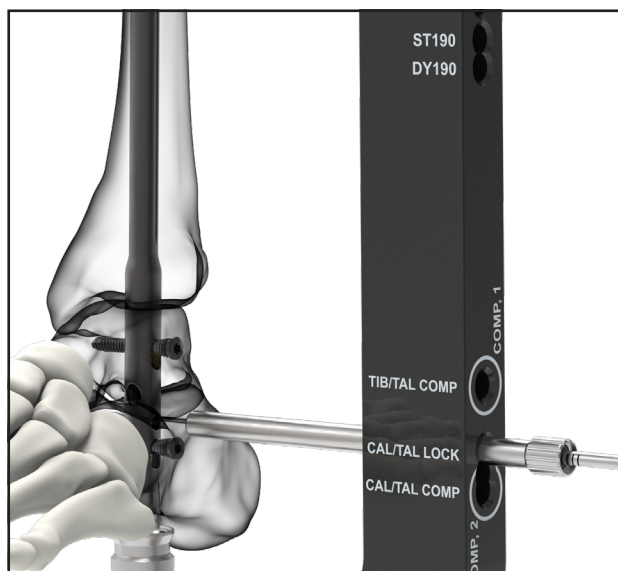

3. Once the 5mm Drill Guide is removed, insert the appropriately sized 5mm Screw through the Guide Tube and into the Nail using the Retaining Screwdriver and handle, turning in a clockwise direction until the laser mark on the Driver meets the end of the Guide Tube, or when the head of the 5mm Screw is snug against the calcaneus.

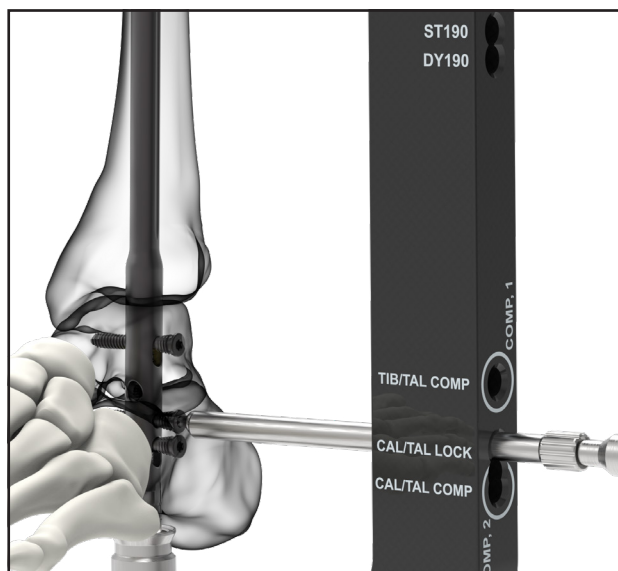

4. Verify the 5mm Screw length and placement under fluoroscopy. **Once satisfied with subtalar compression, the Stage 2 Driver can be removed from the base of the Nail.**

DYNAMIC TALUS SCREW INSERTION (Stage 1)

1. Rotate the Outrigger to the *lateral position* for the operative side (R/L). Confirm that the Drill Guide Construct is aligned in the “TIB/TAL COMP” hole in the Outrigger. Make a small stab incision at the proximal Drill Guide site, then perform blunt dissection and position the Drill Guide to abut the bone. Drill bicortically from lateral to medial through the Drill Guide using the 4/5mm M/L Drill (Long or Short) 20-70mm Scale in the talus.

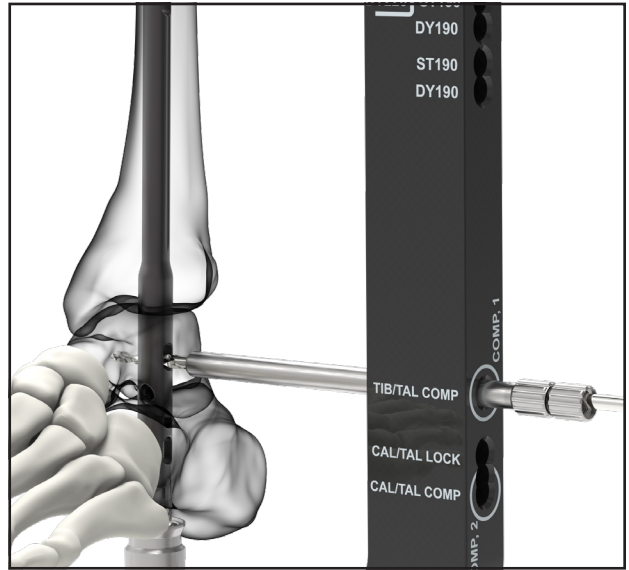

2. 5mm Screw depth can be measured from the Drill with the Drill Guide in place and/or using the SUCCESSION Depth Gauge 20-120mm after removal of the 5mm Drill Guide.

Note: A Countersink is available, when needed, to facilitate seating of M/L screws in dense bone. It is intended for use only through the Guide Tube and must not be operated under power.

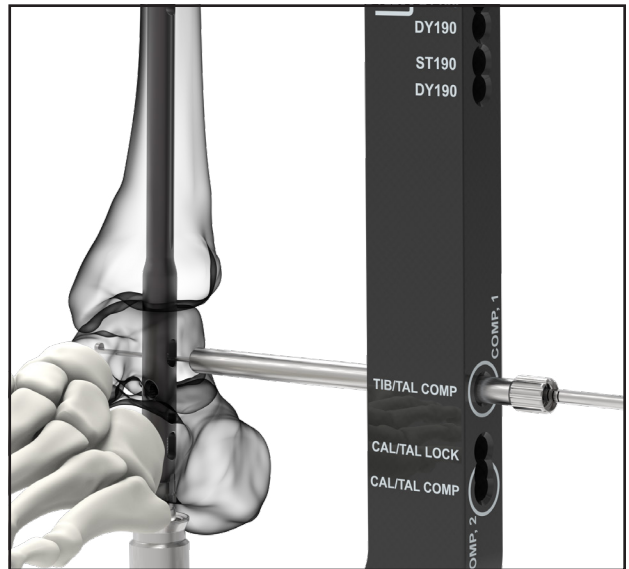

3. Once the 5mm Drill Guide is removed, insert the appropriately sized 5mm Screw through the Guide Tube and into the Nail using the Retaining Screwdriver and handle, turning in a clockwise direction until the laser mark on the Driver meets the end of the Guide Tube, or when the head of the 5mm Screw is snug against the talus.

4. Verify the 5mm Screw length and placement under fluoroscopy.

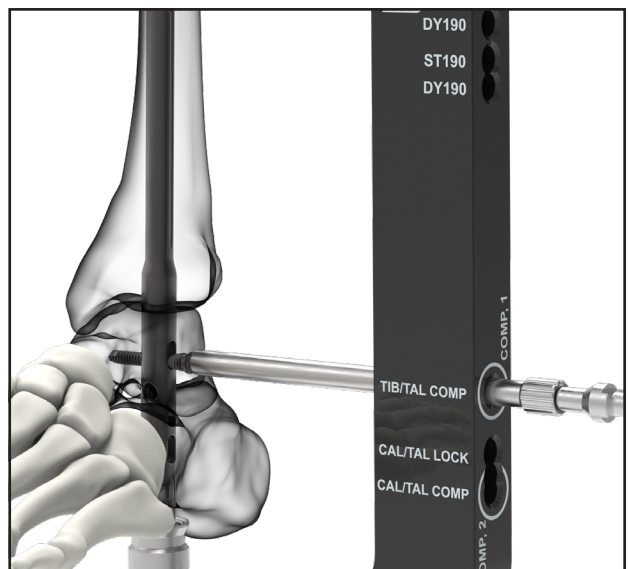

Stage 1 Driver



DYNAMIC TALUS SCREW INSERTION (Stage 1)

5. Locate the Stage 1 Driver and attach to a Ratcheting Handle. Insert the Stage 1 Driver into the base of the Outrigger and into the Nail base. Once interference is felt with the cradle, rotate clockwise, mechanically compressing the talus to the tibia.

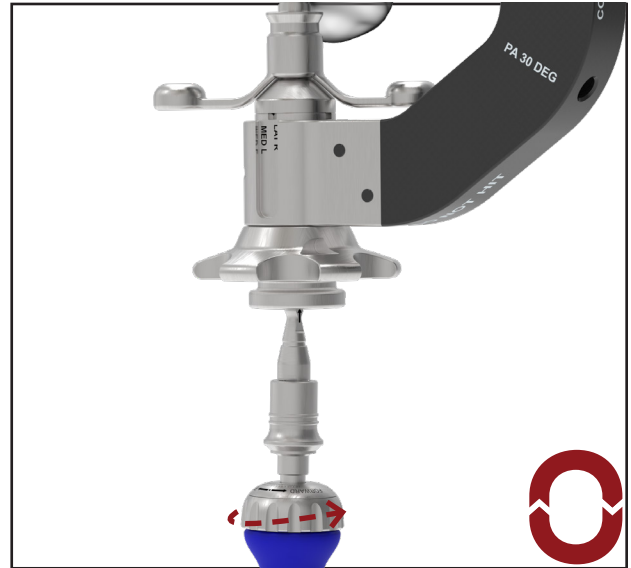

6. Up to 5mm of internal compression is offered at Stage 1 (TIB/TAL). Check fluoroscopy and remove the Stage 1 Driver once adequate compression has been attained.

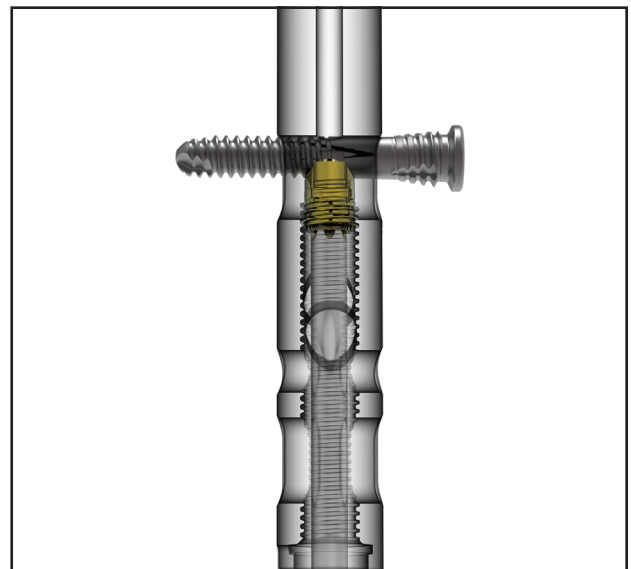

LOCKING CALCANEUS SCREW INSERTION

1. Keep the Outrigger in the *lateral position* for the operative side (R/L). Rotate the External Compressor clockwise until compression at the tibiotalar and subtalar joints occurs. Confirm that the Drill Guide Construct is aligned in the “CAL/TAL LOCK” hole in the Outrigger. Make a small stab incision at the proximal Drill Guide site, then perform blunt dissection and position the Drill Guide to abut the bone. Drill bicortically from lateral to medial through the Drill Guide using the 4/5mm M/L Drill (Long or Short) 20-70mm Scale in the calcaneus.

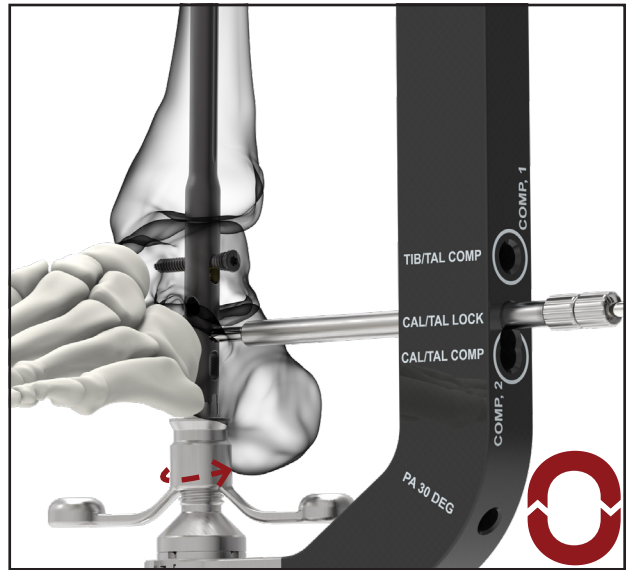

2. 5mm Screw depth can be measured from the Drill with the Drill Guide in place and/or using the SUCCESSION Depth Gauge 20-120mm after removal of the 5mm Drill Guide.

Note: A Countersink is available, when needed, to facilitate seating of M/L screws in dense bone. It is intended for use only through the Guide Tube and must not be operated under power.

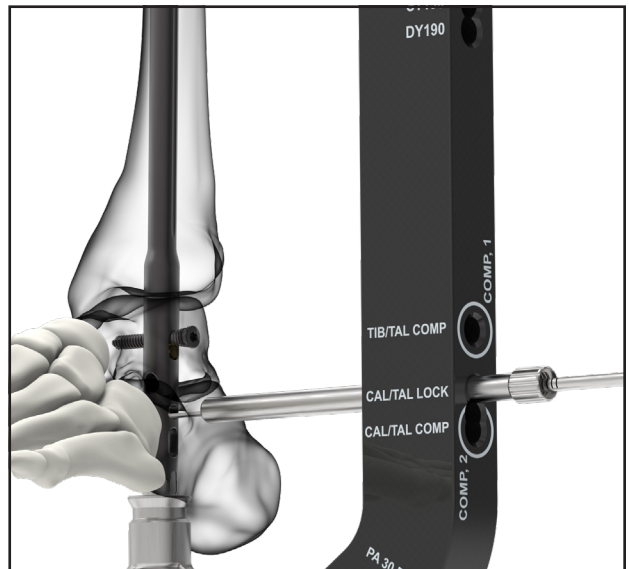

3. Once the 5mm Drill Guide is removed, insert the appropriately sized 5mm Screw through the Guide Tube and into the Nail using the Retaining Screwdriver and handle, turning in a clockwise direction until the laser mark on the Driver meets the end of the Guide Tube, or when the head of the 5mm Screw is snug against the calcaneus.

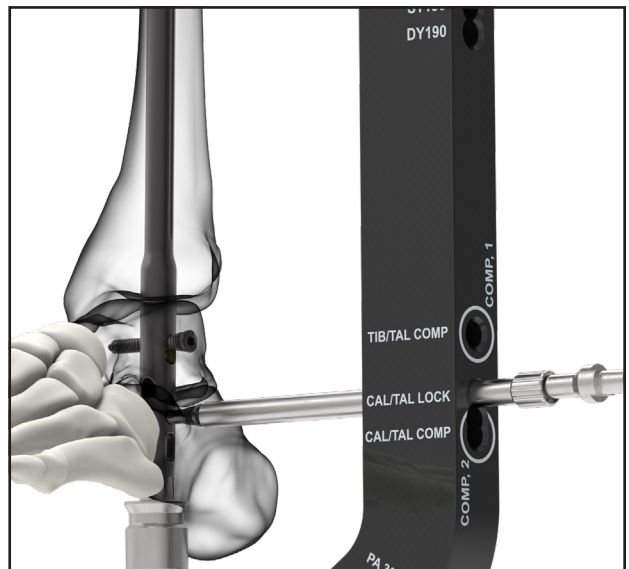

TALUS SCREW INSERTION

1. Rotate the Outrigger to the *lateral position for the operative side (R/L)*. Rotate the External Compressor (a) clockwise until compression at the tibiotalar and subtalar joints occur. Confirm that the Drill Guide Construct is aligned in the “TIB/TAL COMP” hole in the Outrigger. Make a small stab incision at the proximal Drill Guide site, then perform blunt dissection and position the Drill Guide to abut the bone. Drill bicortically from lateral to medial through the Drill Guide using the 4/5mm M/L Drill (Long or Short) 20-70mm Scale in the talus.

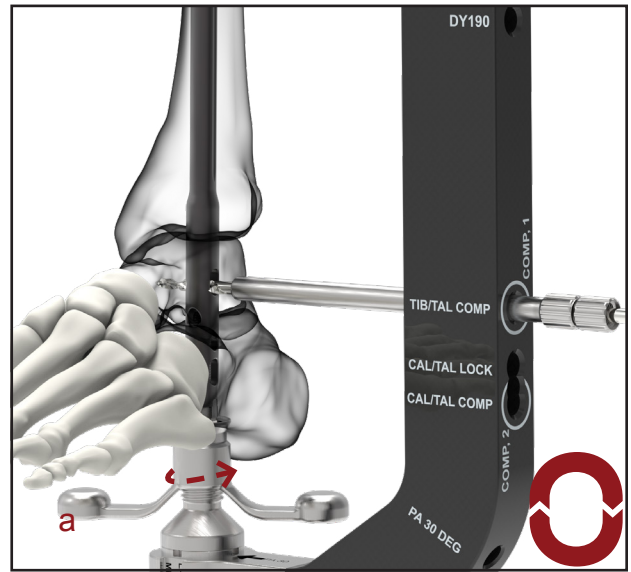

2. 5mm Screw depth can be measured from the Drill with the Drill Guide in place and/or using the SUCCESSION Depth Gauge 20-120mm after removal of the 5mm Drill Guide.

Note: A Countersink is available, when needed, to facilitate seating of M/L screws in dense bone. It is intended for use only through the Guide Tube and must not be operated under power.

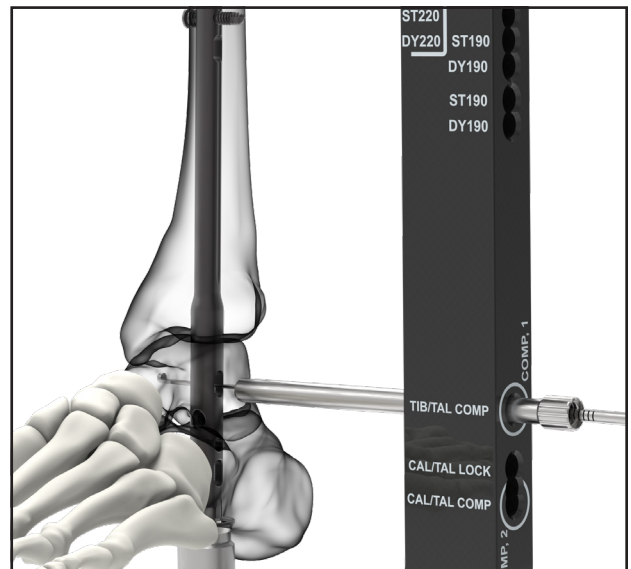

3. Once the 5mm Drill Guide is removed, insert the appropriately sized 5mm Screw through the Guide Tube and into the Nail using the Retaining Screwdriver and handle, turning in a clockwise direction until the laser mark on the Driver meets the end of the Guide Tube, or when the head of the 5mm Screw is snug against the talus.

4. Verify the 5mm Screw length and placement under fluoroscopy. Repeat the steps above to place the second 5mm Screw.

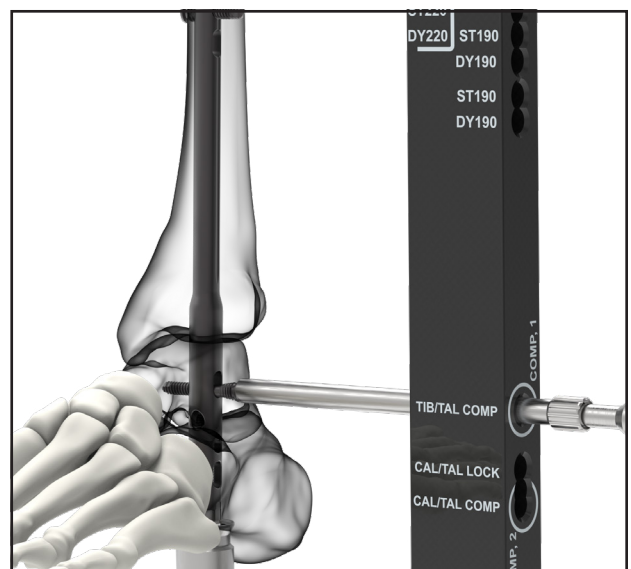

LOCKING CALCANEUS SCREW INSERTION

1. Keep the Outrigger in the *lateral position* for the operative side (R/L). Confirm that the Drill Guide Construct is aligned in the “CAL/TAL LOCK” hole in the Outrigger. Make a small stab incision at the proximal Drill Guide site, then perform blunt dissection and position the Drill Guide to abut the bone. Drill bicortically from lateral to medial through the Drill Guide using the 4/5mm M/L Drill (Long or Short) 20-70mm Scale in the talus.

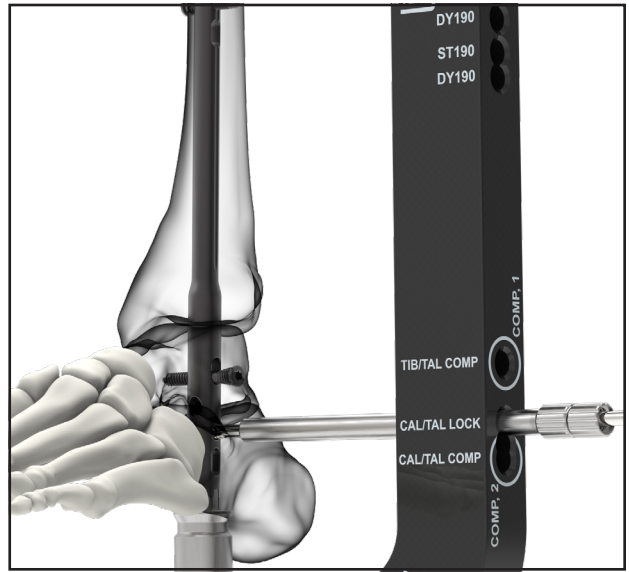

2. 5mm Screw depth can be measured from the Drill with the Drill Guide in place and/or using the SUCCESSION Depth Gauge 20-120mm after removal of the 5mm Drill Guide.

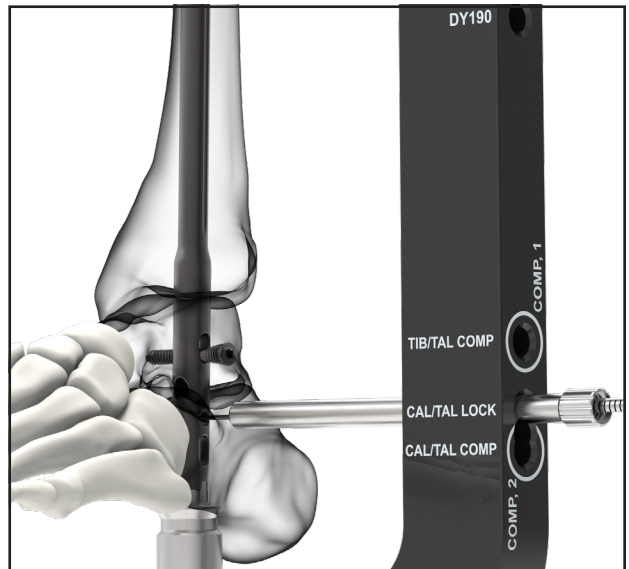

Note: A Countersink is available, when needed, to facilitate seating of M/L screws in dense bone. It is intended for use only through the Guide Tube and must not be operated under power.

3. Once the 5mm Drill Guide is removed, insert the appropriately sized 5mm Screw through the Guide Tube and into the Nail using the Retaining Screwdriver and handle, turning in a clockwise direction until the laser mark on the Driver meets the end of the Guide Tube, or when the head of the 5mm Screw is snug against the calcaneus.

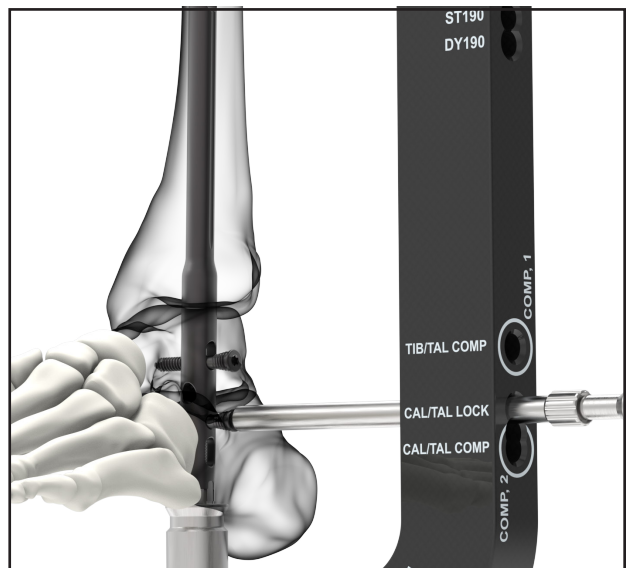

PA SCREW INSERTION

1. Rotate the Outrigger to the *posterior position*. Confirm that the Drill Guide Construct is aligned in the “PA 30 DEG” hole in the Outrigger. Make a small stab incision at the proximal Drill Guide site, then perform blunt dissection and position the Drill Guide to abut the bone. Drill bicortically from posterior to anterior through the Drill Guide using the PA Step Drill 45-120mm Scale from the calcaneus to the talus.

2. 6mm Screw depth can be measured from the Drill with the Drill Guide in place and/or using the SUCCESSION Depth Gauge 20-120mm after removal of the PA Drill Guide.

3. Once the PA Drill Guide is removed, insert the appropriately sized 6mm Screw through the Guide Tube and into the Nail using the Retaining Screwdriver and handle, turning in a clockwise direction until the laser mark on the Driver meets the end of the Guide Tube, or when the head of the 6mm Screw is snug against the calcaneus.

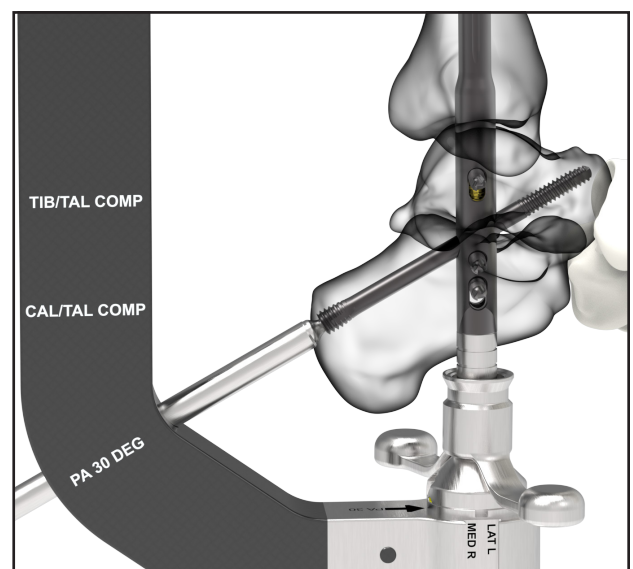
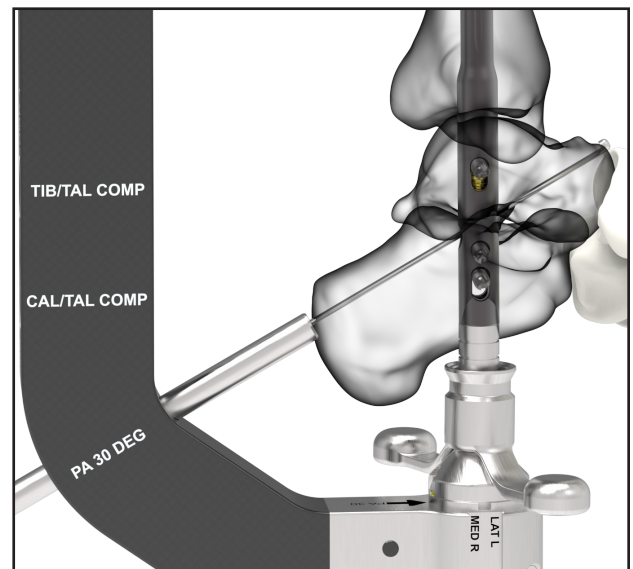
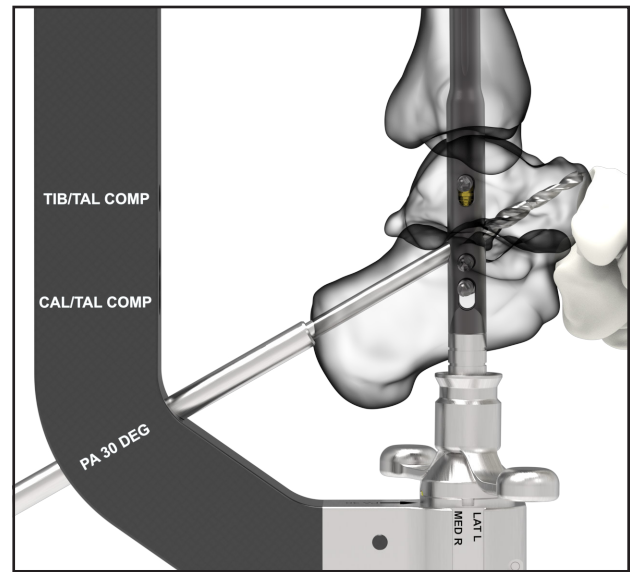

OUTRIGGER REMOVAL

Verify the Nail and Screw placement under multiple fluoroscopic views. Using the Draw Bolt Socket Adapter (a), remove the Nail Draw Bolt from the Nail by turning counterclockwise until the Outrigger is released from the Nail.

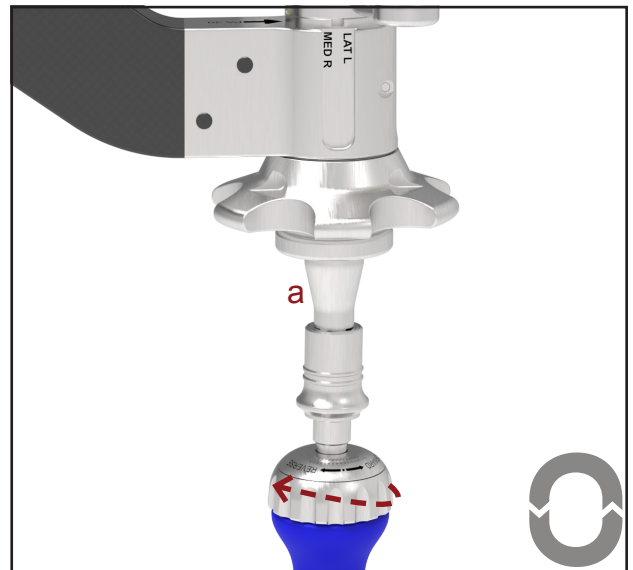

END CAP INSERTION

It is recommended to use an End Cap as it adds stability to the internal compression mechanism at Stage 2.

Once the desired End Cap has been chosen, simply attach it to the Self Retaining Driver and insert into the distal end of the Nail. Secure the End Cap by rotating in a clockwise direction.

Precaution: If an End Cap is not used, bony ingrowth may occur, potentially increasing difficulty of removal.

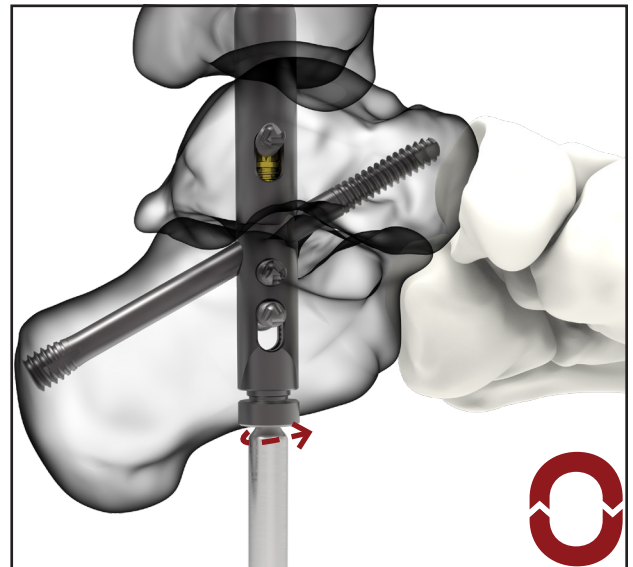

IMPLANT REMOVAL

If revision or removal of the Nail is required, begin by removing the End Cap, the 5mm Screws, and the 6mm P/A Screw. Next, attach the Extraction Adaptor to the distal end of the Nail by threading it in using the larger “top hat” (a). To securely fasten the Extraction Adaptor to the Nail, tighten it by turning the smaller “top hat” (b). Thread Slap Hammer into the Extraction Adaptor. Gently use the Slap Hammer to withdraw the Nail.

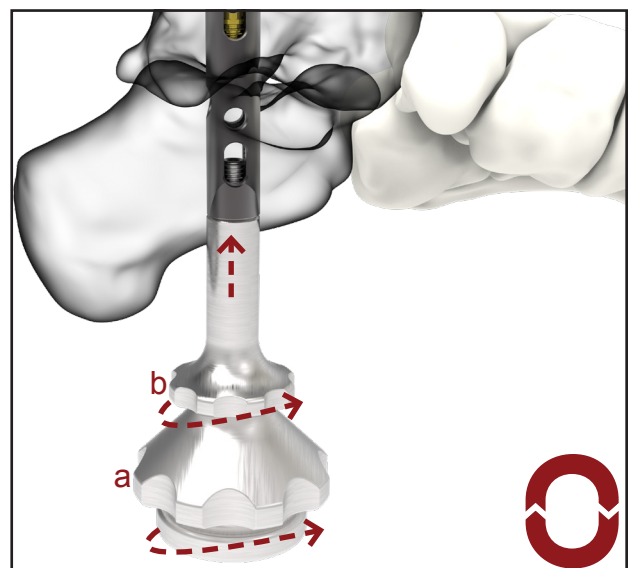

The first interlocking screw determines final orientation of the Nail within the ankle. In cases of severe talar compromise and limited bone stock, it may be advantageous to target this screw site first. This approach is particularly beneficial when using an anterior exposure, as it allows for precise alignment while helping to avoid interference with the fibula during talar screw insertion.

The following is a condensed alternative technique beginning after Nail Entry Site has been established.

1. Position the proximal end of the Primary Jig centrally within the talar head using an anterior approach medial to the first metatarsal. Proper jig placement is critical to ensure accurate wire alignment through the tibial canal.
2. Once the proximal end of the primary jig is set, position the distal end approximately 2cm plantar to the fat pad of the heel.

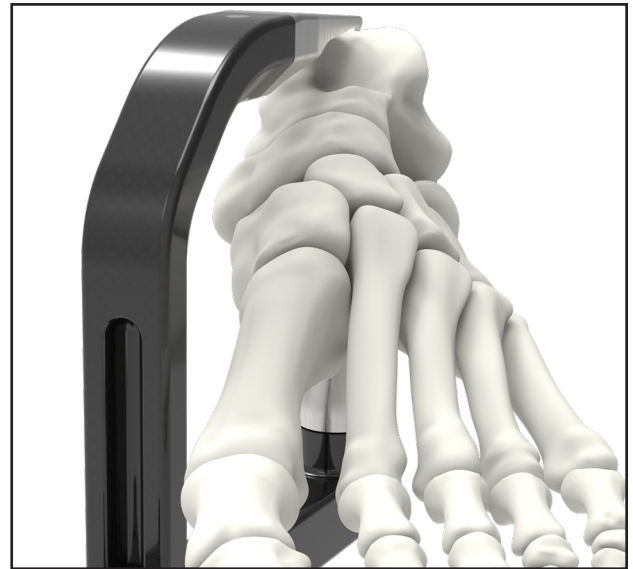

3. A plantar incision is made just distal to the plantar fat pad, slightly lateral to midline. Blunt dissection is carried down to the plantar calcaneus to avoid disruption of nearby neurovascular bundles. The tip of the 3.2mm Starter Wire is placed against the plantar aspect of the calcaneus.

Tip: A lateral fluoroscopic image may be utilized to confirm correct distal to proximal trajectory of the Starter Wire.

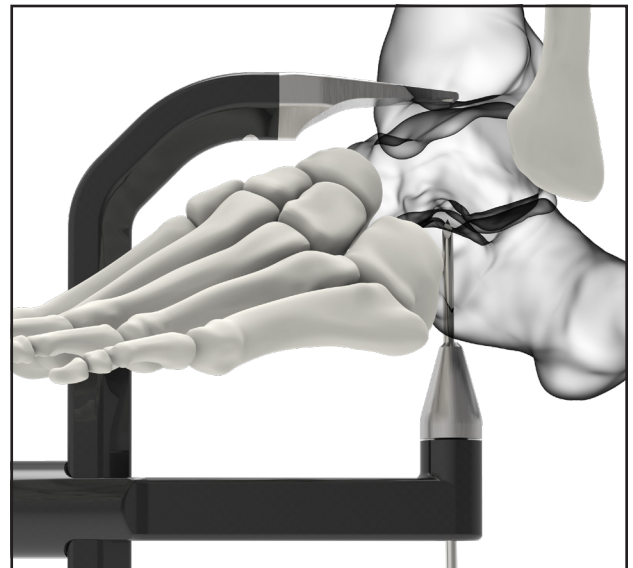

ENTRY / MODULAR REAMING

Proceed with Entry / Modular Reaming as outlined in the steps on page 11 - 12.

NAIL INSERTION

Proceed with Nail Insertion as outlined in the steps on page 21 - 22.

SCREW HOLE DEPTH AND BONE STOCK

1. When placing a hindfoot nail, it is critical to ensure appropriate depth of the talar screw hole within the Nail, particularly when the distal end of the fibula remains intact. This screw typically passes near the fibula, and improper depth can lead to cortical breach. Therefore, fluoroscopic evaluation should confirm that the planned screw path safely avoids the fibula, while still achieving adequate fixation within the talus.

Tip: The use of the guide tube may be helpful when analyzing planned screw path.

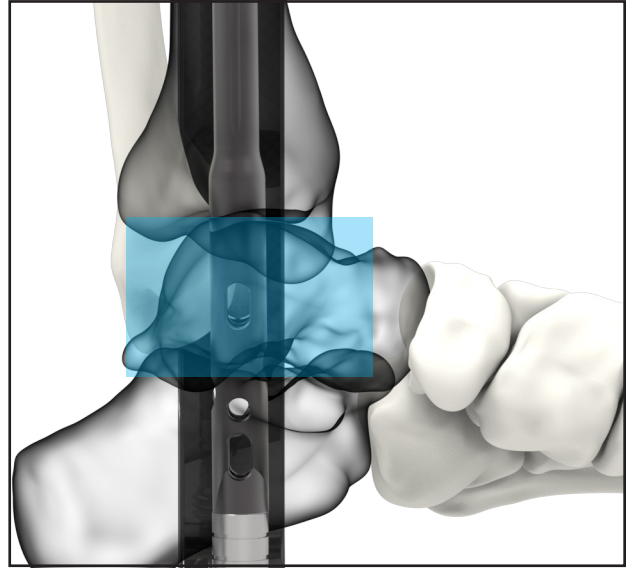

2. Once the talar screw hole has been properly evaluated and cleared relative to the fibula, attention should turn to ensuring that the calcaneus has sufficient bone stock to accommodate the distal screws. Adequate depth and positioning of the Nail must allow the calcaneal screw holes to engage solid cancellous bone without breaching the plantar cortex of the subtalar joint. This ensures stable fixation and minimizes risk of screw loosening or failure at the calcaneal interface.

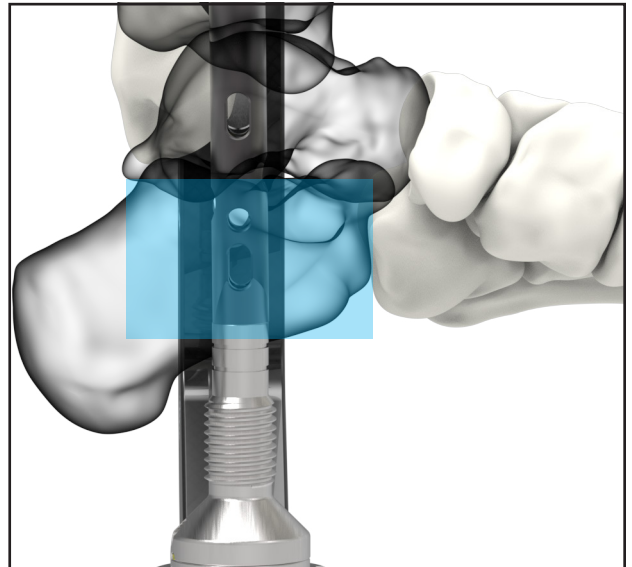

TALUS SCREW INSERTION

1. Rotate the Outrigger to the *lateral position* for the operative side (R/L). Confirm that the Drill Guide Construct is aligned in the “TIB/TAL COMP” hole in the Outrigger. Make a small stab incision at the proximal Drill Guide site, then perform blunt dissection and position the Drill Guide to abut the bone. In some cases, it may be necessary to remove small portions of distal fibula to allow for optimal positioning and unobstructed access to the talus. Drill bicortically from lateral to medial through the Drill Guide using the 4/5mm M/L Drill (Long or Short) 20-70mm Scale in the talus.

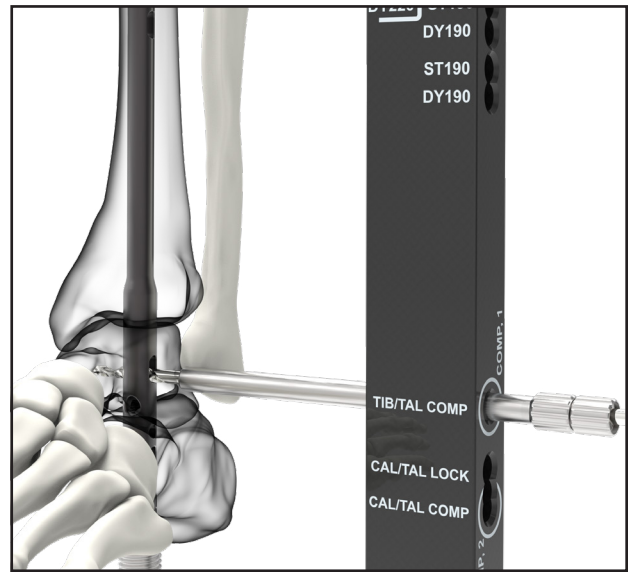

2. 5mm Screw depth can be measured from the Drill with the Drill Guide in place and/or using the SUCCESSION Depth Gauge 20-120mm after removal of the 5mm Drill Guide.

Note: A Countersink is available, when needed, to facilitate seating of M/L screws in dense bone. It is intended for use only through the Guide Tube and must not be operated under power.

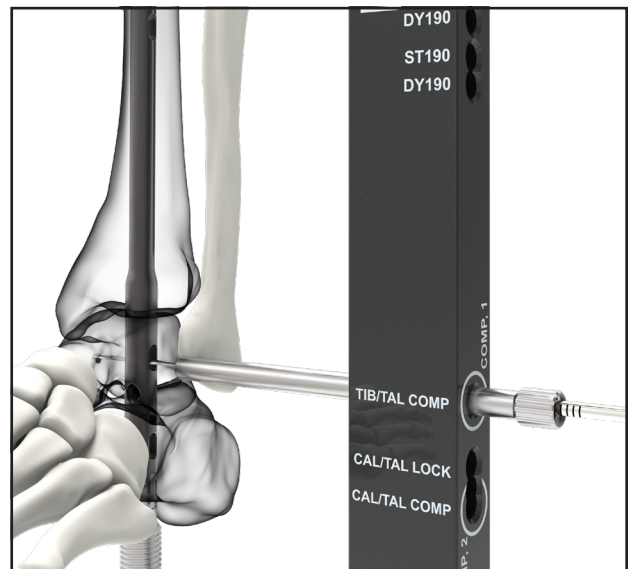

3. Once the 5mm Drill Guide is removed from the Guide Tube, insert the appropriately sized 5mm Screw through the Guide Tube and into the Nail using the Retaining Screwdriver and handle, turning in a clockwise direction until the laser mark on the Driver meets the end of the Guide Tube, or when the head of the 5mm Screw is snug against the talus.

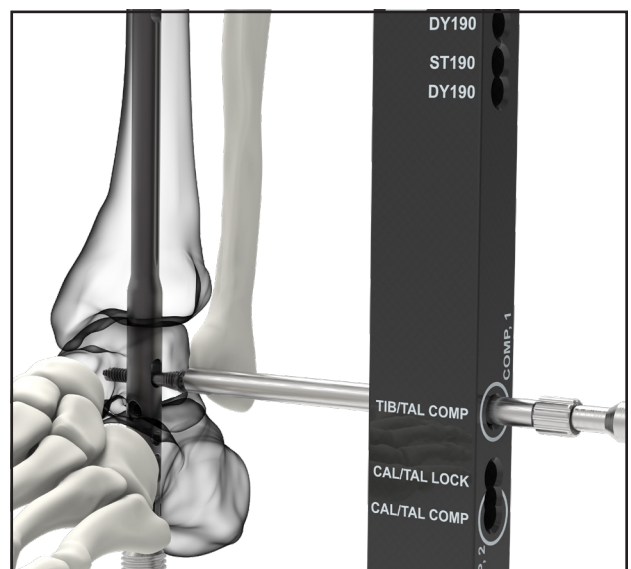

PROXIMAL TIBIAL SCREW INSERTION

1. Rotate the Outrigger to the *medial position* for the operative side (R/L). Confirm that the Drill Guide construct is aligned for the intended configuration (static or dynamic). Make a small stab incision at the proximal Drill Guide site, then perform blunt dissection and position the Drill Guide to abut the bone. Drill bicortically from medial to lateral through the Drill Guide using the 4/5mm M/L Short Drill 20-70mm Scale in the talus. Leave the Drill in place, then proceed to the second screw and repeat the process using the 4/5mm M/L Long Drill 20-70mm Scale.

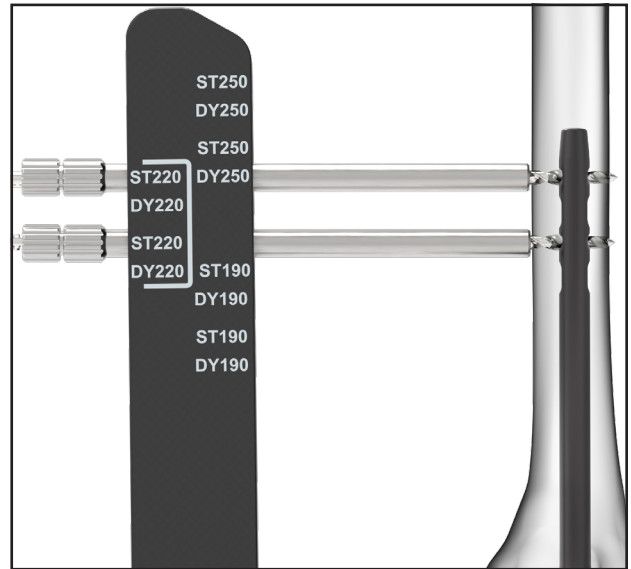

2. 5mm Screw depth can be measured from the Drill with the Drill Guide in place and/or using the SUCCESSION Depth Gauge 20-120mm after removal of the 5mm Drill Guide.

Note: A Countersink is available, when needed, to facilitate seating of M/L screws in dense bone. It is intended for use only through the Guide Tube and must not be operated under power.

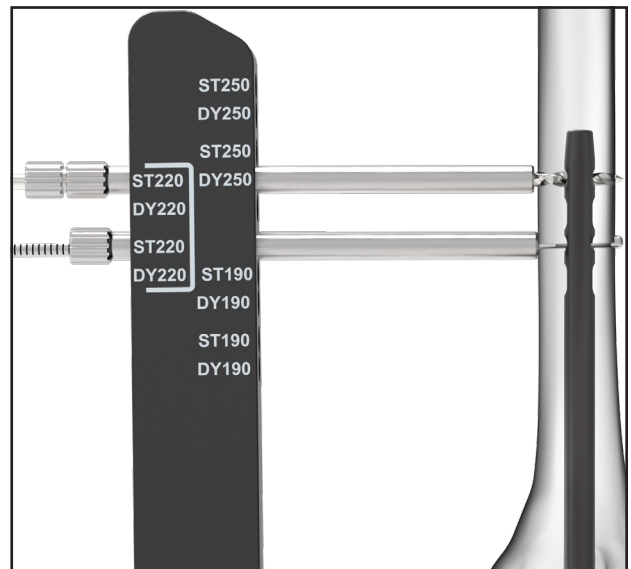

3. Once the 5mm Drill Guide is removed, insert the appropriately sized 5mm Screw through the Guide Tube and into the Nail using the Retaining Screwdriver and handle, turning in a clockwise direction until the laser mark on the Driver meets the end of the Guide Tube, or when the head of the 5mm Screw is snug against the tibia.

4. Verify the 5mm Screw length and placement under fluoroscopy. Repeat the steps above to place the second 5mm Screw.

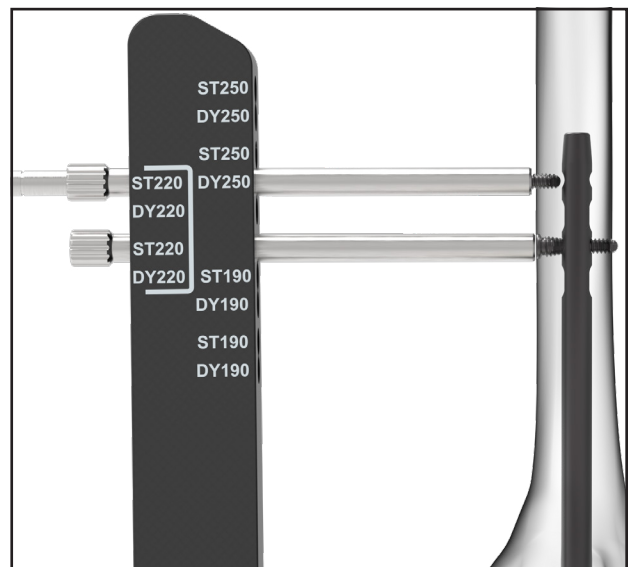

Stage 1 Driver



DYNAMIC TALUS SCREW COMPRESSION (Stage 1)

5. Locate the Stage 1 Driver and attach to a Ratcheting Handle. Insert the Stage 1 Driver into the base of the Outrigger and into the Nail base. Once interference is felt with the cradle, rotate clockwise, mechanically compressing the talus to the tibia.

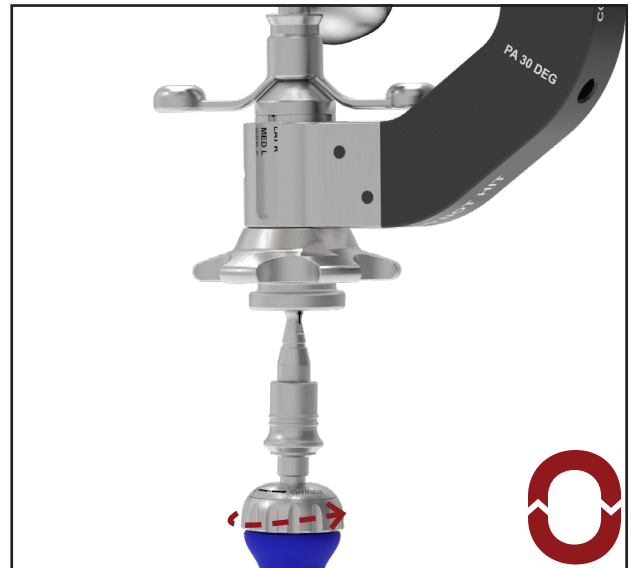

6. Up to 5mm of internal compression is offered at Stage 1 (TIB/TAL). Check fluoroscopy and remove the Stage 1 Driver once adequate compression has been attained.

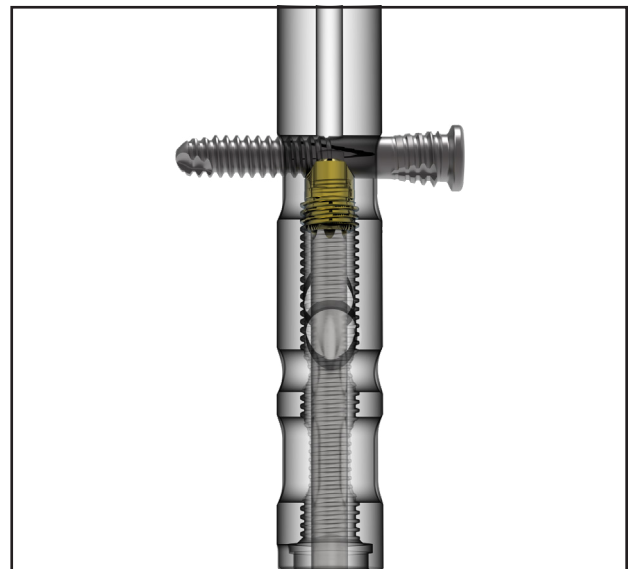

DYNAMIC CALCANEUS SCREW INSERTION (Stage 2)

1. Keep the Outrigger in the *lateral position* for the operative side (R/L). Confirm that the Drill Guide Construct is aligned in the “CAL/TAL COMP” hole in the Outrigger. Make a small stab incision at the proximal Drill Guide site, then perform blunt dissection and position the Drill Guide to abut the bone. Drill bicortically from lateral to medial through the Drill Guide using the 4/5mm Drill M/L (Long or Short) 20-70mm Scale in the calcaneus.

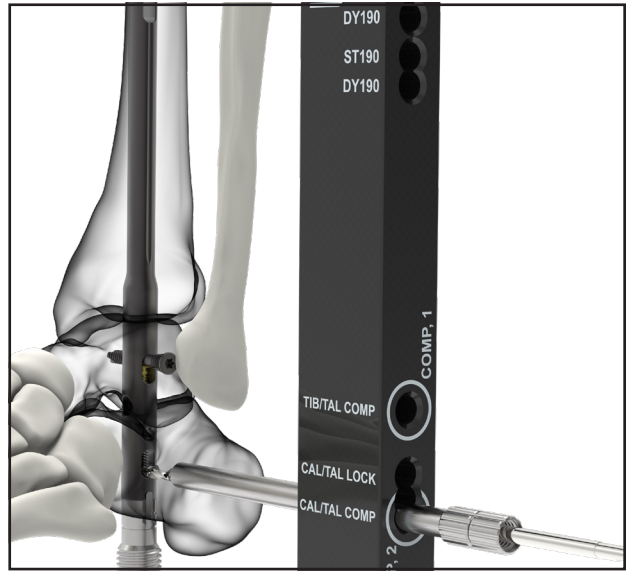

2. 5mm Screw depth can be measured from the Drill with the Drill Guide in place and/or using the SUCCESSION Depth Gauge 20-120mm after removal of the 5mm Drill Guide.

Note: A Countersink is available, when needed, to facilitate seating of M/L screws in dense bone. It is intended for use only through the Guide Tube and must not be operated under power.

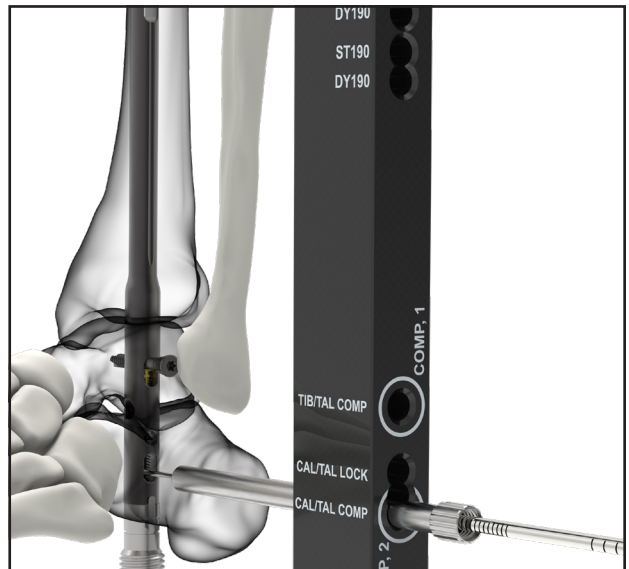

3. Once the 5mm Drill Guide is removed, insert the appropriately sized 5mm Screw through the Guide Tube and into the Nail using the Retaining Screwdriver and handle, turning in a clockwise direction until the laser mark on the Driver meets the end of the Guide Tube, or when the head of the 5mm Screw is snug against the calcaneus.

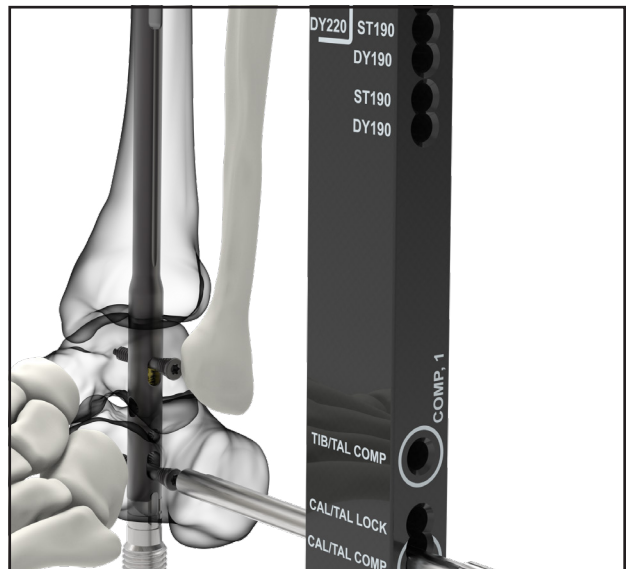

Stage 2 Driver



DYNAMIC CALCANEUS SCREW INSERTION (Stage 2)

4. Locate the Stage 2 Driver and attach to a Ratcheting Handle. Insert the Stage 2 Driver into the base of the Outrigger and into the Nail base. Once interference is achieved with the internal threading, rotate clockwise, mechanically compressing the calcaneus to the talus.

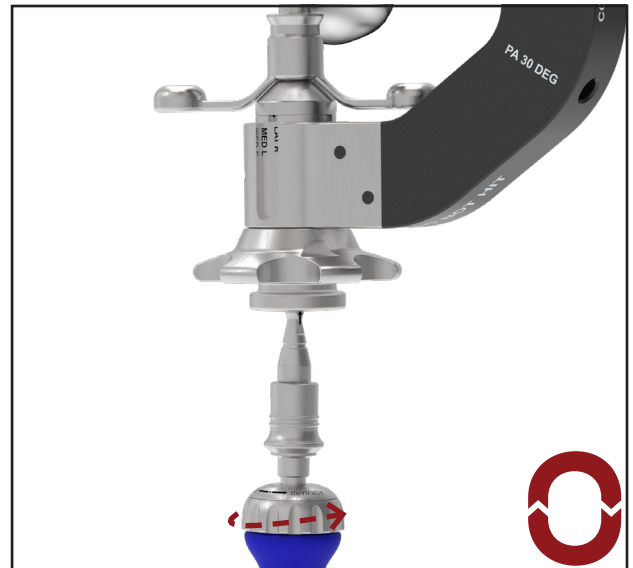

5. Up to 5mm of internal compression is offered at Stage 2 (CAL/TAL). Check fluoroscopy once adequate compression has been attained.

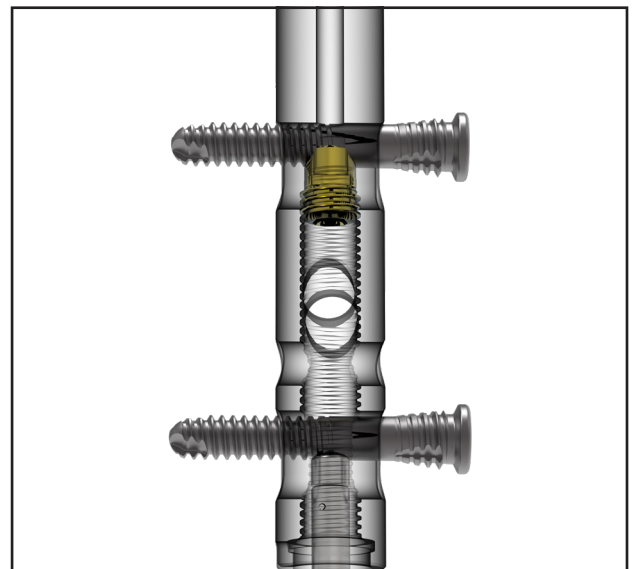

**DO NOT REMOVE THE STAGE 2 DRIVER FROM BASE OF NAIL -
WAIT UNTIL THE NEXT STEP HAS BEEN COMPLETED**

LOCKING CALCANEUS SCREW INSERTION

1. Keep the Outrigger in the *lateral position* for the operative side (R/L). Confirm that the Drill Guide Construct is aligned in the “CAL/TAL LOCK” hole in the Outrigger. Make a small stab incision at the proximal Drill Guide site, then perform blunt dissection and position the Drill Guide to abut the bone. Drill bicortically from lateral to medial through the Drill Guide using the 4/5mm M/L Drill (Long or Short) 20-70mm Scale in the calcaneus.

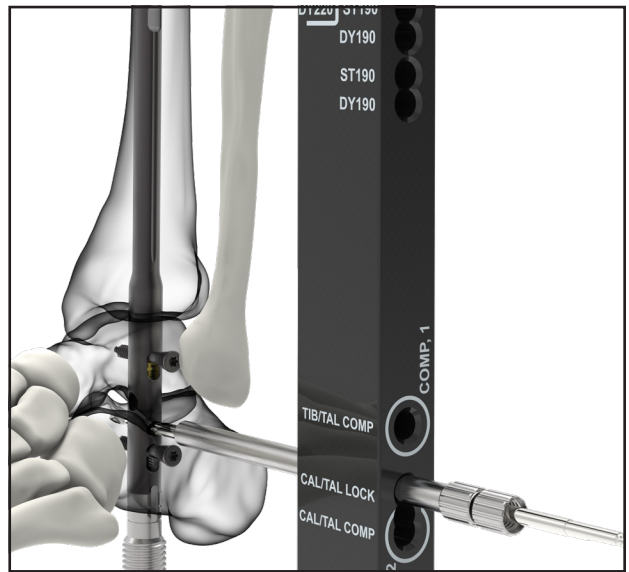

2. 5mm Screw depth can be measured from the Drill with the Drill Guide in place and/or using the SUCCESSION Depth Gauge 20-120mm after removal of the 5mm Drill Guide.

Note: A Countersink is available, when needed, to facilitate seating of M/L screws in dense bone. It is intended for use only through the Guide Tube and must not be operated under power.

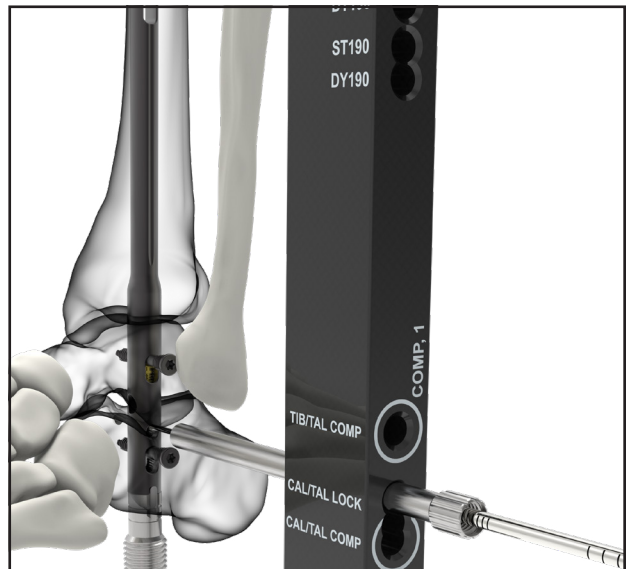

3. Once the 5mm Drill Guide is removed, insert the appropriately sized 5mm Screw through the Guide Tube and into the Nail using the Retaining Screwdriver and handle, turning in a clockwise direction until the laser mark on the Driver meets the end of the Guide Tube, or when the head of the 5mm Screw is snug against the calcaneus.

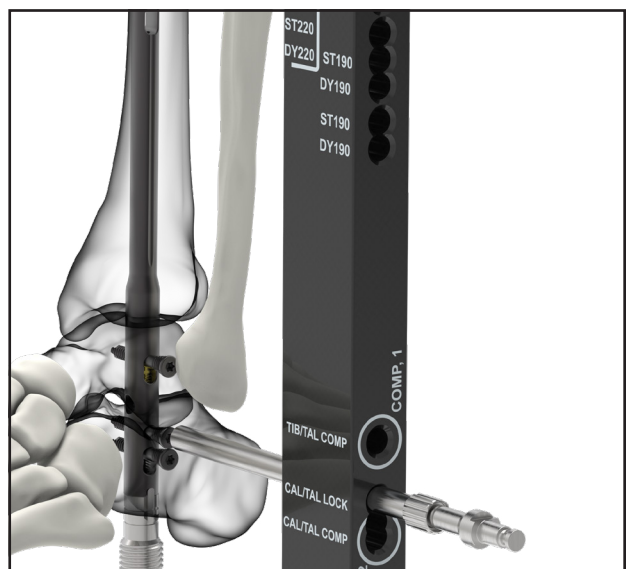

4. Verify the 5mm Screw length and placement under fluoroscopy. **Once satisfied with subtalar compression, the Stage 2 Driver can be removed from the base of the Nail.**

PA SCREW INSERTION

1. Rotate the Outrigger to the *posterior position*. Confirm that the Drill Guide Construct is aligned in the “PA 30 DEG” hole in the Outrigger. Make a small stab incision at the proximal Drill Guide site, then perform blunt dissection and position the Drill Guide to abut the bone. Drill bicortically from posterior to anterior through the Drill Guide using the PA Step Drill 45-120mm Scale from the calcaneus to the talus.

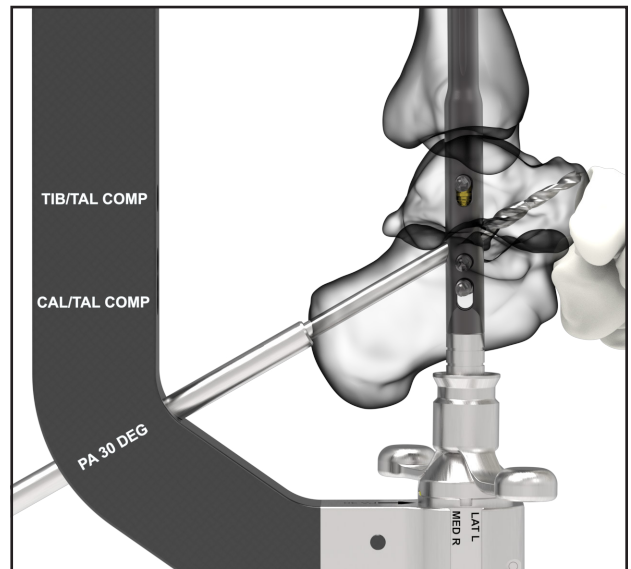

2. 6mm Screw depth can be measured from the Drill with the Drill Guide in place and/or using the SUCCESSION Depth Gauge 20-120mm after removal of the PA Drill Guide.

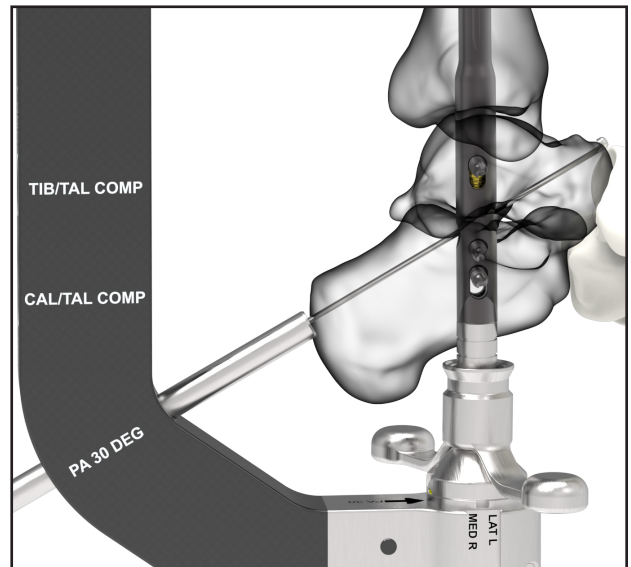

3. Once the PA Drill Guide is removed, insert the appropriately sized 6mm Screw through the Guide Tube and into the Nail using the Retaining Screwdriver and handle, turning in a clockwise direction until the laser mark on the Driver meets the end of the Guide Tube, or when the head of the 6mm Screw is snug against the calcaneus.

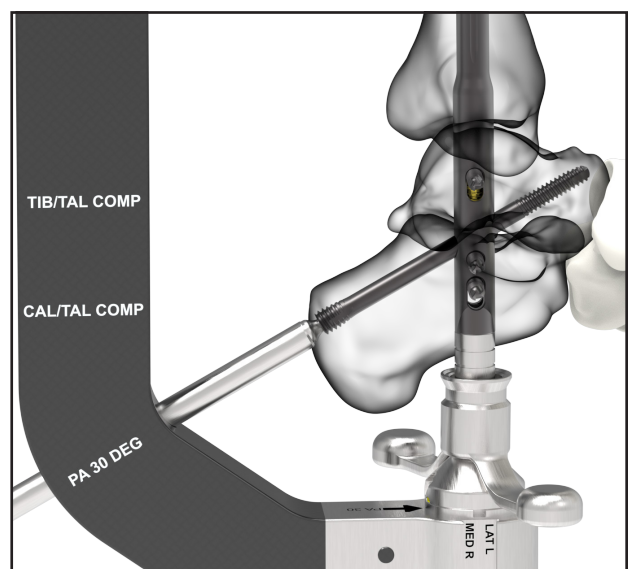

SUCCESSION[®] ANKLE FUSION NAIL SYSTEM

Tray Layout (Top Level)

- A** Stage 1 Driver
- B** Stage 2 Driver
- C** Retaining Screwdriver
- D** Trocar
- E** Depth Gauge 20-120mm
- F** Guide Tube
- G** 5mm Drill Guide
- H** 6mm Drill Guide
- I** Countersink
(located underneath H)
- J** 10.0 to 13.0mm Modular Reamer Heads
- K** Secondary 13.5mm Reamer
- L** Primary 8mm Reamer
(located underneath K)
- M** Nitinol Shaft 4.95mm
(located underneath J and K)
- N** Nail Draw Bolt
- O** Draw Bolt Adapter
- P** Slotted Stage
- Q** Impactor
- R** Axial Ratcheting Cannulated Handle
- S** Pistol Ratcheting Cannulated Handle
- T** Outrigger

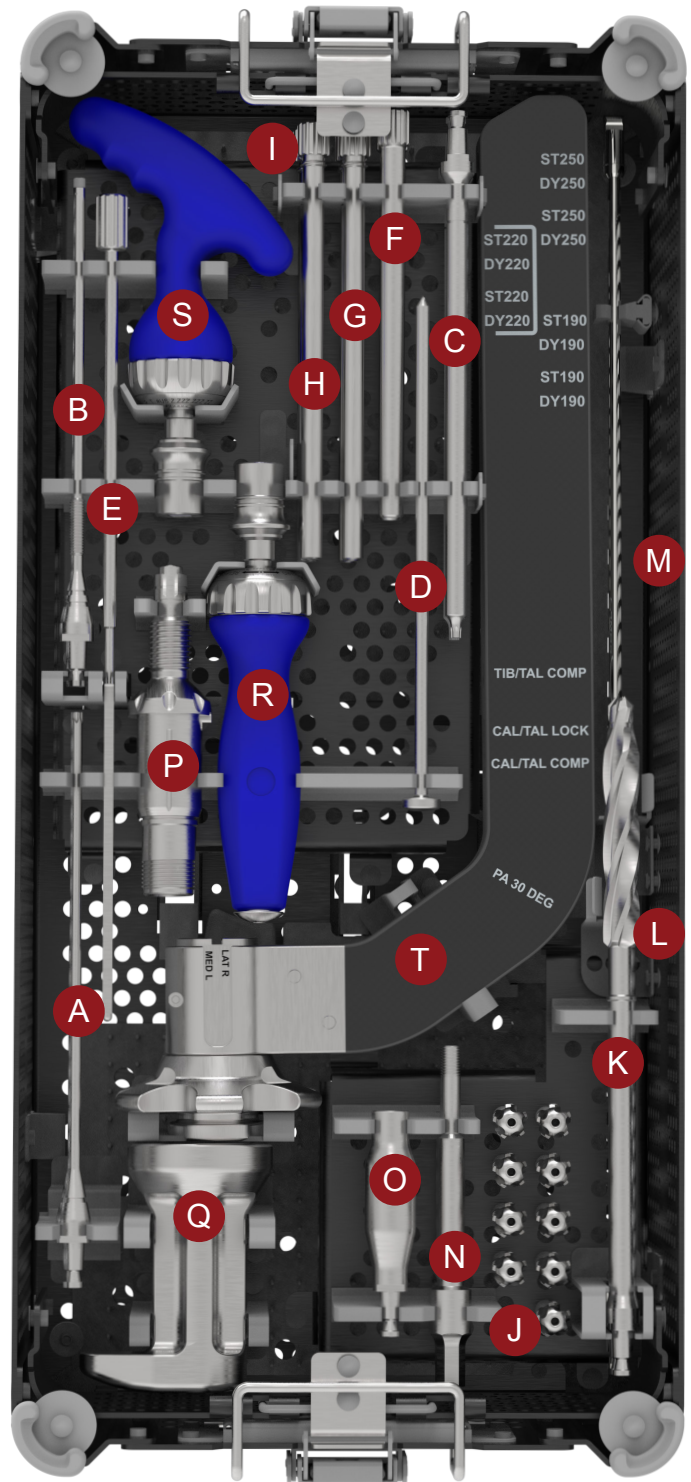

SUCCESSION[®] ANKLE FUSION NAIL SYSTEM

Tray Layout (Bottom Level)

- T** Primary Jig
- U** External Compressor

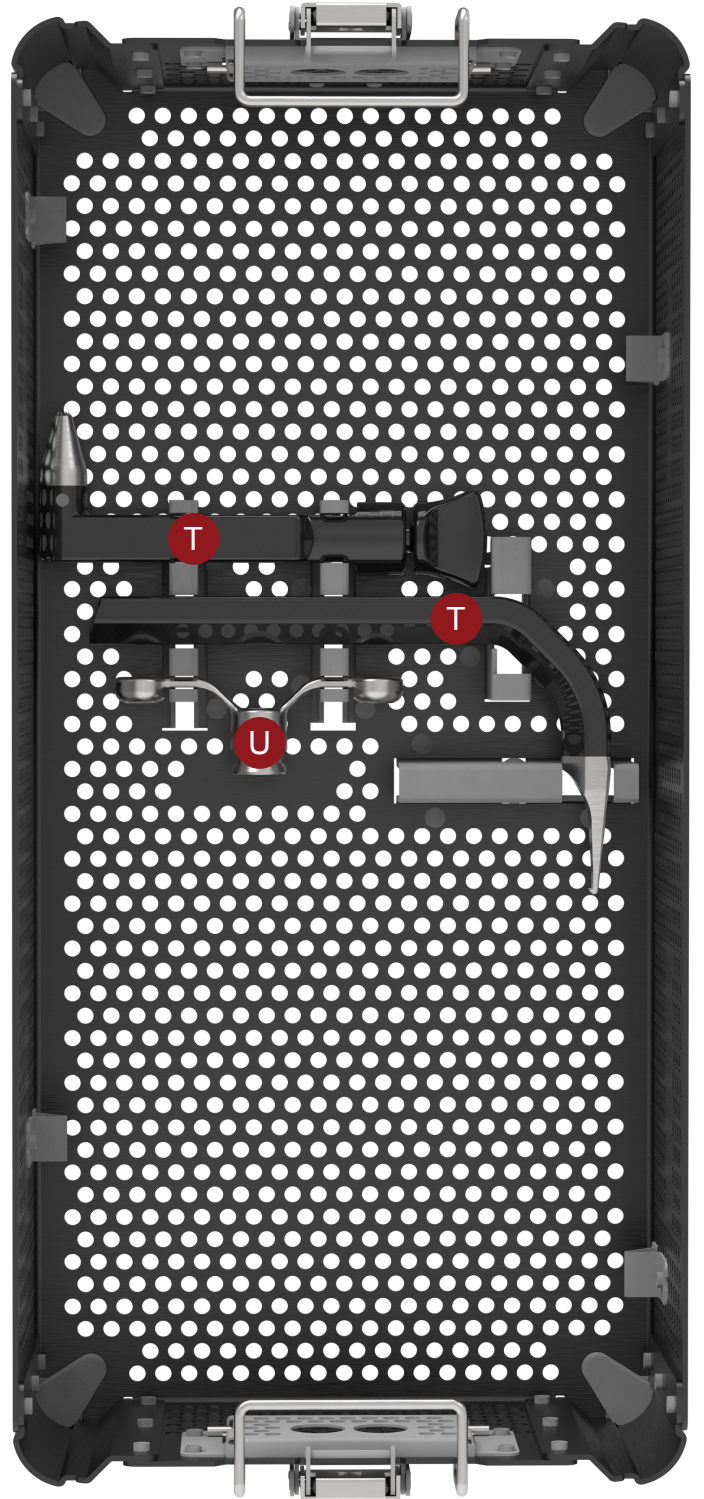



 Ortho Solutions UK Limited
West Station Business Park,
Spital Road, Maldon, Essex.
CM9 6FF, United Kingdom

T: +44 (0)1621 843 599
E: sales@orthosol.com

Ortho Solutions Inc - USA
209 10th Avenue South
Suite #416,
Nashville, TN 37203

T: +1 (615) 899 FOOT 3668
E: us.sales@orthosol.com

Ortho Solutions Pty - Australia
PO Box 1330,
Milton,
QLD. 1406, Australia

T: +61 (0)408 846821
E: salespty@orthosol.com

Rx only

Caution: Federal Law (USA)
restricts this device to sale by
or on the order of a physician

www.orthosol.com

OS TD 00245_24 - Rev 02
Effective Date: June 2026

© 2023 Ortho Solutions UK Ltd. Ortho Solutions and the OS logo
are registered trademarks of Ortho Solutions UK Ltd.

